

Assembling instructions
Montage Anweisungen
Montaje instructie
Noticia de montagen
Istruzioni per il montaggio
Instruções de montaje

TOPWOOD

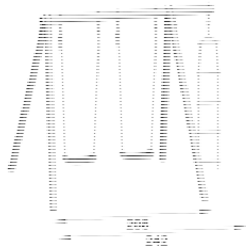

TO300
Réf.15345



TO400
Réf.15455



TO401
Réf.15460



TO402
Réf.15490



TO500
Réf.15457



TO502
Réf.15458

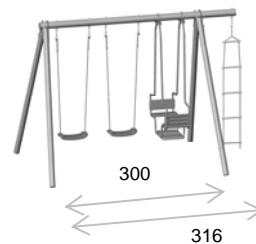

TO503
Réf.15555



TO600
Réf.15673

TRIGANO JARDIN
Usine du Boulay
41310 – Cormenon, France

Gamme TOPWOOD sans plate forme - H 2,30m

F A LIRE IMPERATIVEMENT AVANT DE COMMENCER LE MONTAGE DE VOTRE PRODUIT - SCHELLEMENT BETON IMPERATIF

UK IT IS ESSENTIAL TO READ THE MANUAL BEFORE STARTING TO ASSEMBLY YOUR PRODUCT - MUST BE FIXED IN CONCRETE

D VOR DER MONTAGE DES ARTIKELS UNBEDINGT DURCHLESEN - MUSS UNBEDINGT EINBETONIERT WERDEN

NL LEES DIT VERPLICHT EN GRONDIG DOOR VOORDAT U UW TOESTEL GAAT MONTEREN - HET IS NOODZAKELIJK TE BEVESTIGEN MET GRONDANKERS

I LEGGERE ATTENTAMENTE PRIMA DI INIZIARE IL MONTAGGIO DEL PRODOTTO - O CHUMBAMENTO É IMPERATIVO

SP DE LECTURA IMPRESINDIBLE ANTES DE EMPEZAR CON EL MONTAJE DEL PRODUCTO - ESSERE FISSATO SALDAMENTE NEL CEMENTO

P A LER IMPERATIVAMENTE ANTES DE COMECAR A MONTAGEM DO SEU PRODUTO - EMPOTRAMIENTO IMPERATIVO

AGE (an)
AGE (years)
ALTER
IDADE
LEEFTIJD
ETA - EDAD
5 - 12

120 min



10
13

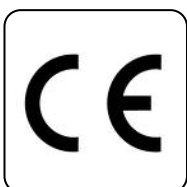

F Veuillez garder impérativement la notice de montage qui vous sera utile pour l'entretien de votre produit. Ne pas apporter de modifications au produit, et tout changement doit être fait avec des pièces d'origines.

UK It is imperative that you keep the assembling instructions, which be of use for product maintenance. Not to bring modifications to the product, and any change must be made with parts of origins.

D Bewahren Sie unbedingt die Montageanleitung auf, die Sie zur Wartung und Pflege Ihres Artikels brauchen. Modifizierungen zum Produkt, und jeder Änderung nicht zu bringen, muß mit Details von Ursprüngen gemacht warden.

NL Bewaar de gebruiksaanwijzing zorgvuldig, deze zal nuttig zijn voor het onderhoud van uw produkt. Niet te doen voor wijzigingen in het product, en elke verandering moet worden gemaakt met details van oorsprongsgebieden

I Guarde imperativamente as intruções de montagem, que serão úteis para a manutenção do seu produto. Non portare modifichie al prodotto, ed alcun cambio deve essere fatto con dettagli di origini.

SP Conservare il manuale di montaggio per le ulteriori operazioni di manutenzione. No traer modificaciones al producto, y cualquier cambio debe ser hecho con los detalles de origenes.

P Conserve cuidadosamente las intruções de montaje, ya que le servirán para el mantenimiento de su producto. Não trazer modificações ao produto e qualquer mudança deve ser feita com detalhes de origens.

F

Zone de sécurité : 2,00 m.

- aucun objet en appui sur le produit
- Recouvrir le béton de 5 cm de terre meuble

UK

Safety area : 2,00 m.

- No object around the product
- Cover the concrete dies with a 5cm layer of soil

D

Sicherheitsbereich: 2,00 m.

- Kein Gegenstände in der Nähe der Rutsche belassen
- 5cm Rasenüberdeckung erforderlich im Leiterbereich und im Auslaufbereich

NL

Veiligheidszone : 2,00 m.

- Geen enkel voorwerp rondom het toestel
- Bedek de betonblokken met 5cm losse aarde

I

Zona di sicurezza : 2,00 m.

- Nessun oggetto intorno al prodotto
- Ricoprire i dadi in cemento di 5cm terra mobile

SP

Area de seguridad : 2,00 m.

- Ningún objecto alrededor del producto
- Recubrir el hormigón con 5cm de tierra blanda

P

Zona de segurança : 2,00 m.

- Nenhum objecto em redor do produto
- Abranger o betão de 5cm de terra móvel.

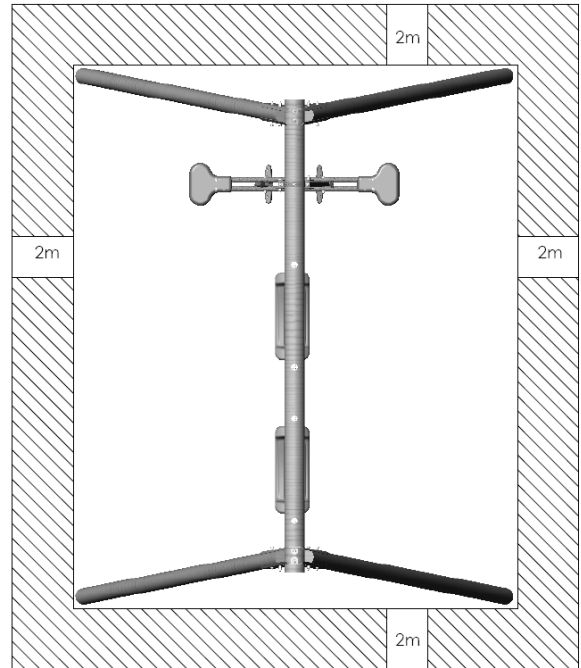

F - Votre balançoire est prévue pour être montée sur des portiques de hauteurs différentes. Avant d'utiliser votre portique et régulièrement par la suite, contrôler que le dessous du siège de balançoire est toujours compris entre 35 et 50cm par rapport au sol. Si ce n'est pas le cas, procéder impérativement à ce réglage.

GB -Your swing is designed to be gone up on gantries of different sizes. Before using your gantry and regularly there after, controlling that the lower part of the seat of swing always lies between 35 and 50cm compared to the ground. If it is not the case, to carry out this adjustment imperatively.

D - Ihre Schaukel ist vorgesehen, um auf Säulenhallen anderer Größen aufgerichtet zu werden. Bevor Ihre Säulenhalle und regelmäßig später zu benutzen zu kontrollieren, dass die Unterseite des Schaukelsitzes immer zwischen 35 und 50 gelegen wird cm hinsichtlich des Bodens. Wenn es nicht der Fall, diese Einstellung dringend durchzuführen ist.

NL- Uw schommel is voorzien om op portalen van verschillende omvang gestegen te zijn. Alvorens uw portaal te gebruiken en regelmatig vervolgens, controleren dat de onderkant van de zetel van schommel altijd tussen 35 en 50cm ten opzichte van de bodem wordt omvat. Als het niet het geval, verplicht tot dit regelen overgaan is.

I - La vostra altalena è prevista per essere montata su cavalletti di dimensioni diverse. Prima di utilizzare il vostro cavalletto e regolarmente successivamente, controllare che il sotto della sede d'altalena è sempre compreso tra 35 e 50cm rispetto al suolo. Se non è il caso, procedere imperativamente a questa messa a punto.

SP - Su columpio está previsto subirse sobre pórticos de tamaños diferentes. Antes de utilizar su pórtico y regularmente más tarde, controlar que la parte inferior de la sede de columpio siempre se incluye entre 35 y 50cm con relación al suelo. Si no es el caso, proceder imperativamente a este ajuste.

P - O vosso baloiço está previsto para ser montado sobre pórtico de dimensões diferentes. Antes de utilizar o vosso pórtico e regularmente seguidamente, controlar que o abaixo da sede de baloiço sempre é compreendido entre 35 e 50 cm em relação ao solo. Se não é o caso, proceder imperativamente a este ajustamento.

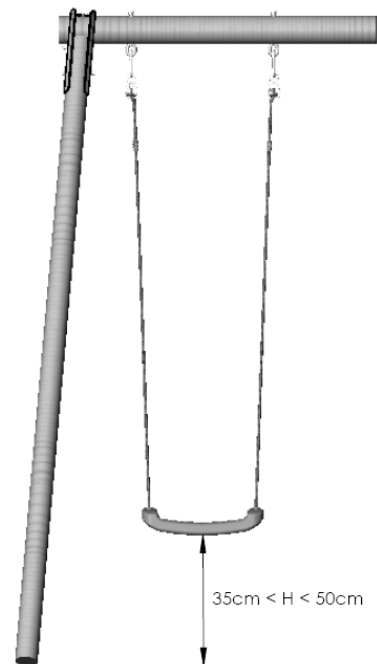

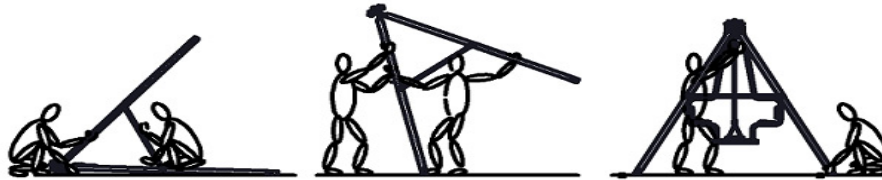

- Scellement béton impératif
- Must be fixed in concrete
- Muss unbedingt einbetoniert werden
- Het is noodzakelijk te bevestigen met grondankers
- O chumbamento é imperativo
- Essere fissato saldamente nel cemento
- Empotramiento imperativo

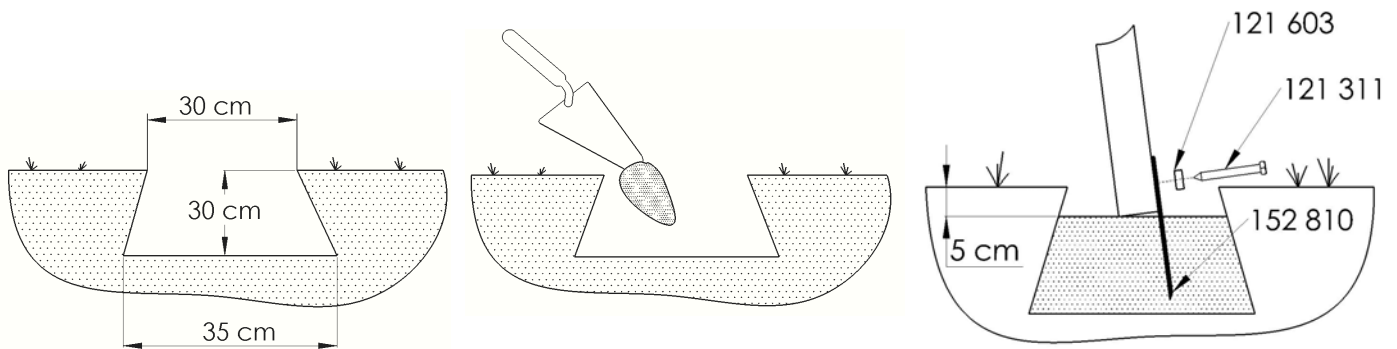

FR - Pour mesurer les écartements entre les pieds avant de faire vos plots de scellement, tirer modérément les pieds vers l'extérieur du portique pour être sûr d'obtenir l'angle de 95° minimum (comme figure ci-contre).

GB - Pull the feet a little bit away from the frame to ensure the angle is at least 95° (see figure below) before measuring the distance between the feet and making your mounting blocks.

DE - Um den Abstand zwischen den Füßen zur Bestimmung der Verankerungspunkte zu bemessen, die Füße des Gerüsts leicht nach außen ziehen, um sicherzugehen, dass der Winkel mindestens 95° beträgt (siehe Abbildung oben).

NL - Voor u de afstandblokjes vastmaakt, moet de afstand ertussen gemeten worden. Trek zachtjes de poten naar de buitenzijde van de speelconstructie zodat u een minimale hoek van 95° hebt (zie figuur hierboven).

ES - Para medir las separaciones entre los pies antes de realizar sus juntas de sellado, tire moderadamente de los pies hacia afuera del pórtico para asegurarse de que tiene un ángulo de 95° como mínimo (como figura más arriba).

IT - Per misurare lo scarto tra i piedi prima di procedere al fissaggio definitivo, tirare con moderazione i piedi verso l'esterno della struttura per essere sicuri di avere un angolo di minimo 95° (come mostrato dalla figura qui sopra).

PO - Para medir as distâncias entre os pés antes de fazer os blocos de fixação, puxar moderadamente os pés para o exterior do pórtico para ter a certeza de ter um ângulo de 95° mínimo (como figura acima).

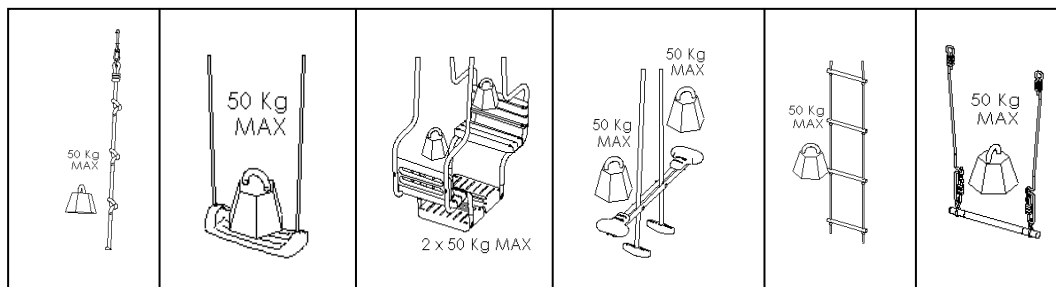
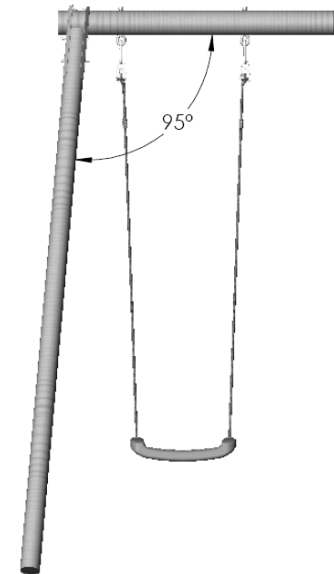

- F** Nous vous précisons que le bois est un produit naturel qui réagit aux variations de température et d'humidité. Des fissures et des fentes peuvent apparaître. C'est tout à fait normal et cela n'affecte en rien la solidité, la durée de vie ou la garantie de ce produit.

- UK** Please be aware, wood is a natural product that re-acts to temperature and humidity variations. Splits and cracks will occur. This is completely normal and does not affect the integrity of your product or your warranty.

- D** Wir erinnern Ihnen, dass das Holz natürlich ist. Es kann sein, dass einige Ritze wegen Feuchtigkeitsveränderungen erscheinen. Das ist ganz normal und das verschlechtert überhaupt nicht die Festigkeit, Lebensdauer oder die Garantie dieses Produkts.

- NL** Wij wijzen er op dat hout een natuurlijk product is dat reageert op temperatuur-en vochtigheidsverschillen. Er kunnen scheurtjes en gleuven optreden. Dit is normaal en doet niets af aan de degelijkheid, de levensduur of de garantie van dit product.

- I** Indicamos-ihe que a madeira é um produto natural que reage às variações de temperatura e de humidade. Rachas e fendas podem aparecer. É normal e isso não afecta em nada a solidez, a duração de vida ou a garantia deste produto.

- SP** Precisiamo che il legno è un prodotto naturale che reagisce alle variazioni di temperatura e di umidità. Possono apparire delle fessure e delle crepe. Ciò è del tutto normale e non ha alcun effetto sulla solidità, la durata di vita o la garanzia di questo prodotto.

- P** Le recordamos que la madera es un producto natural que reacciona a las variaciones de temperatura y humedad. Pueden aparecer fisuras o grietas. Es normal y no afecta en absoluto a la solidez, la vida útil o la garantía del producto.

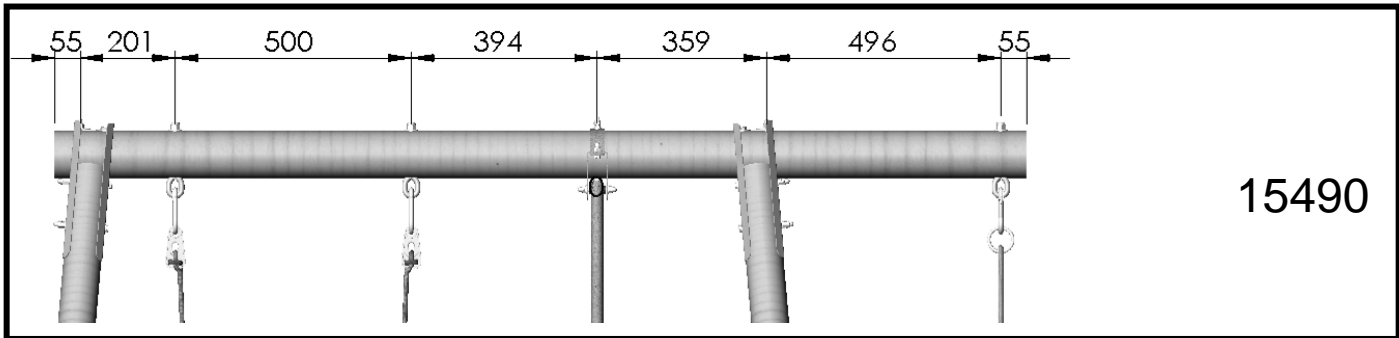
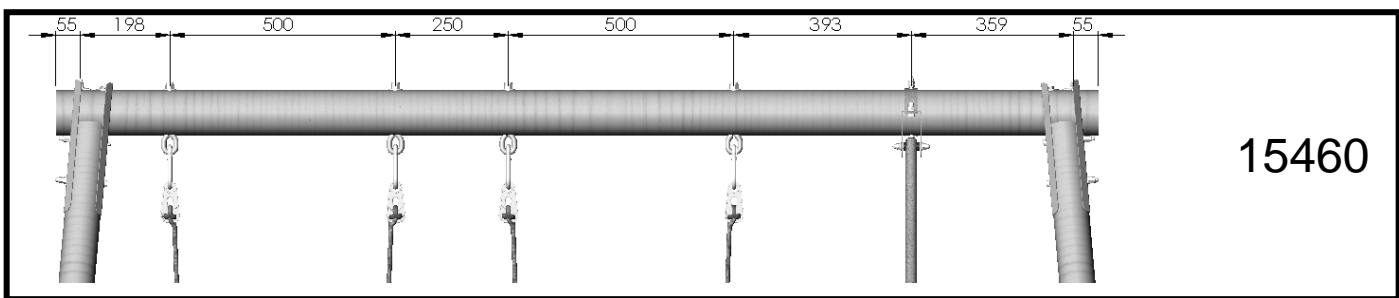
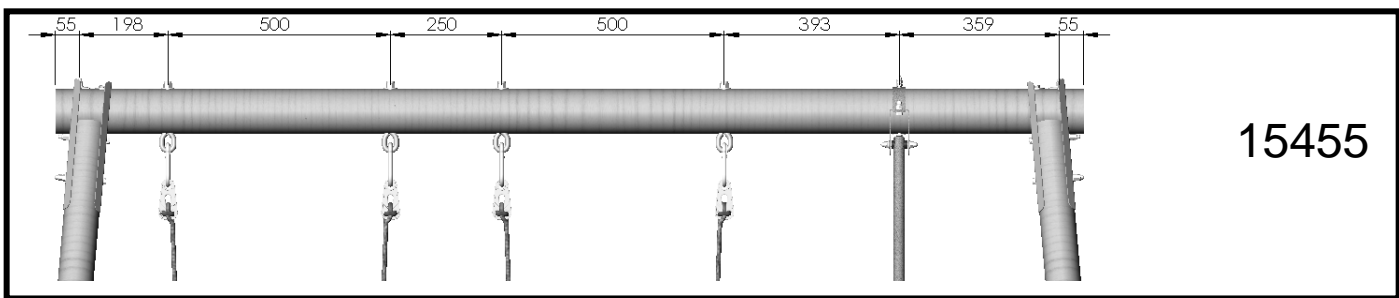
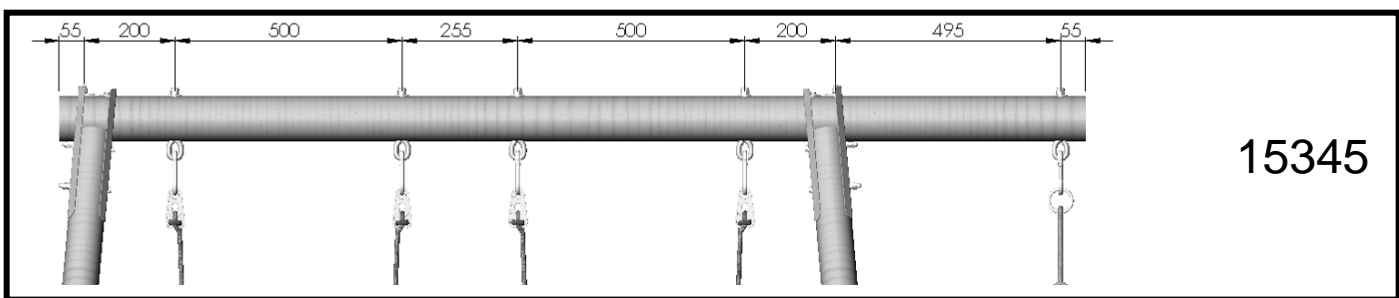

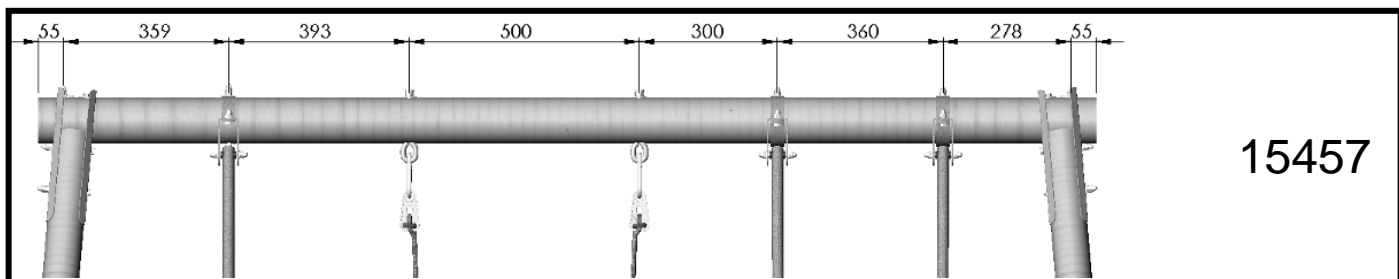

15457

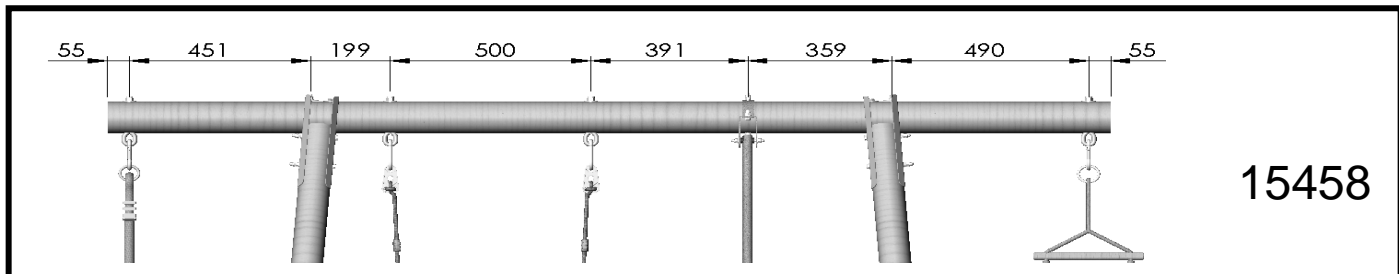

15458

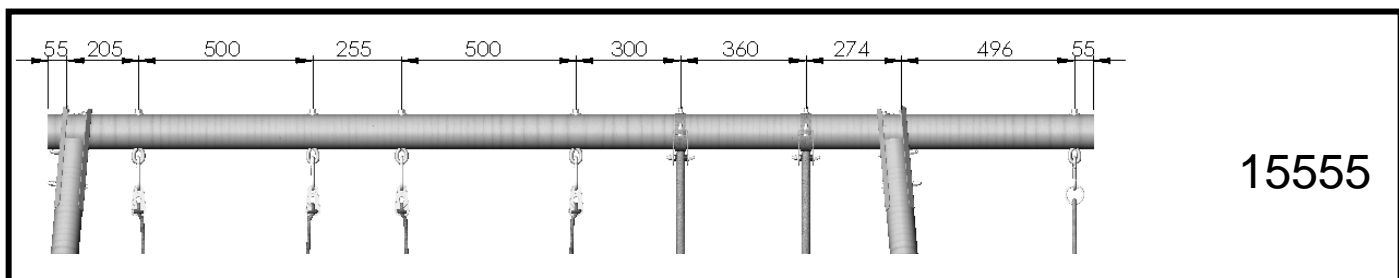

15555

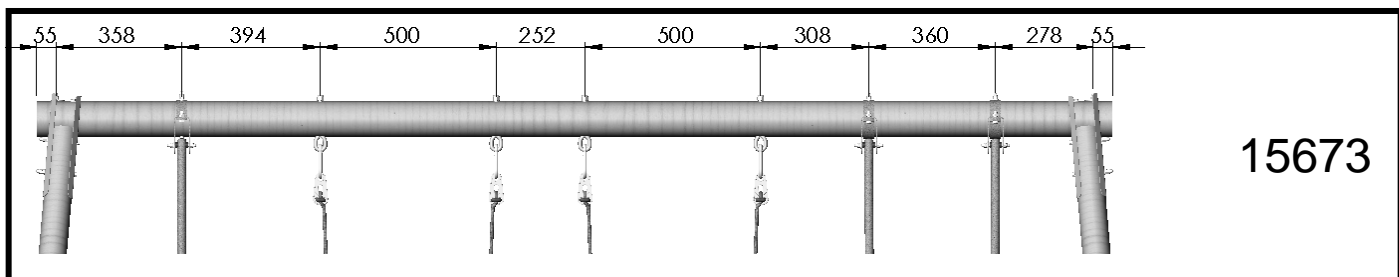

15673

F – Procéder à l'assemblage des pièces avec la visserie, **sans serrer**. Une fois assemblé entièrement, serrer définitivement toutes les vis. Ensuite, sceller **impérativement** votre portique. Pour un portique 6 pieds, l'angle formé par la poutre et les 4 pieds formant la plate-forme doit être de 90°. Par contre l'angle formé par la poutre et les 2 pieds restants doit être au moins de 95° vers l'extérieur. Le non respect de ces consignes risque d'endommager votre produit et annulera la garantie.

GB – Use the screws to assemble the pieces but without **tightening them**. Once entirely assembled tighten all the screws definitively. It is then **essential** to firmly anchor your frame. For frames with 6 legs the angle between the beam and the 4 legs forming the platform should be 90°. However, the outer angle between the beam and the 2 remaining legs should be.

DE – Die Einzerteile mit Hilfe der Schrauben zusammenbauen, dabei die Schrauben **erst nur lose anziehen**. Sobald alles zusammengabaut wurde, alle Schrauben festziehen. Anschließend muss das Gerüst **unbedingt** fest verankert werden. Bei einem Gerüst mit 6 Füßen muss der Winkel zwischen dem Balken und den 4 Füßen, die die Plattform bilden, 90° betragen. Allerdings muss der Außenwinkel zwischen dem Balken und den beiden verbleibenden Füßen mindestens 95° betragen. Wenn diese Vorschriften nicht beachtet werden, besteht das Risiko, dass der Artikel beschädigt wird und die Garantie erlischt.

NL – Ga verder met het samenstellen, stuk per stuk, door gebruik te maken van de schroeven, **zonder deze aan te draaien**. Wanneer alles gemonteerd is, kunt u de schroeven complete aandraaien. Maak hierna uw speelconstructie heel stevig vast. Bij een speelconstructie met 6 poten, moet de hoek gevormd door de balk en de 4 poten die het platform ondersteunen, 90° zijn. Bovendien moet de hoek gevormd door de balk en de resterende 2 poten, 95° zijn naar buiten toe.





















ES – Proceda a ensamblar las piezas con tornillos y pernos, **sin ajustar**. Una vez que haya realizado el ensamblado completo, ajuste definitivamente todos los tornillos. A continuación, es **obligatorio** que selle el portico. Para un pórtico 6 pies, el ángulo entre la viga y los 4 pies que forman la plataforma debe ser de 90°. En cambio, el ángulo formado por la viga y los 2 pies restantes debe ser, como mínimo, de 95° hacia el exterior.

IT – Procedere all'assemblaggio dei pezzi con viti e bulloni, **senza stringere**. Una volta completato l'assemblaggio, stringere definitivamente tutte le viti. In seguito, sigillare **obbligatoriamente** la struttura. Per una struttura a 6 piedi, l'angolo formato dalla trave e dai 4 piedi della piattaforma deve essere di 90°. L'angolo formato dalla trave e dai 2 rimanenti piedi deve invece essere di almeno 95° verso l'esterno.

PO – Procederà montagem das peças com os parafusos, **sem apertar**. Umavez montado completamente apertar definitivamente todo os parafusos. Em seguida, fixar **imperativamente** o seu pórtico. Para o pórtico 6 pés, o ângulo formado pela trave e os 4 pés que formam a plataforma deve ser de 90°. Por outro lado, o ângulo formado pela trave e os 2 pés restantes deve ser de pelo menos 95° para exterior.

























Réf., Rif., Art., Nr., Ref.

Quantité, quantità, anzahl, quantity, aantal, cantidad, quantidade

TOPWOOD 2,30m		TO 300	TO 400	TO 401	TO 402	TO 500	TO 502	TO 503	TO 600
		Ref. 15 345	Ref. 15 455	Ref. 15 460	Ref. 15 490	Ref. 15 457	Ref. 15 458	Ref. 15 555	Ref. 15 673
1		1	1	1	1	1	1	1	1
		125 213	125 215	125 215	125 218	125 217	125 221	125 223	125 230
2	 125 198	4	4	4	4	4	4	4	4
3	 150 777	4	4	4	4	4	4	4	4
4	 152 810	4	4	4	4	4	4	4	4
5	 122 522	1	-	-	1	-	1	1	-
6	 122 723	-	-	-	-	-	1	-	-
7	 151 098	-	-	1	-	-	-	-	-
8	 151 096	-	-	-	-	4	-	4	4
9	 151 117	-	2	2	2	2	2	-	2
10	 122 035	5	4	4	3	2	4	5	4
11	 150 466	-	2	2	2	2	2	-	2
12	 152 818	-	-	-	-	2	-	2	2
13	 150 020	-	1	1	1	3	1	2	3
14	 150 006	-	1	1	1	3	1	2	3
15	 122 830	-	2	2	2	2	2	-	2
16	 122 570-1	4	4	4	2	2	2	4	4
17	 122 840 En option : 122 840	4	4	4	2	2	2	4	4
18	 122 502	-	2	2	2	2	2	-	2
19	 122 519	-	-	-	-	2	-	2	2
20	 122 657-1	-	-	-	-	4	-	4	4
21	 122 834	2	2	2	1	1	1	2	2

Réf., Rif., Art., Nr., Ref.

Quantité, quantità, anzahl, quantity, aantal, cantidad, quantidade

TOPWOOD 2,30m		TO 300 Réf. 15 345	TO 400 Réf. 15 455	TO 401 Réf. 15 460	TO 402 Réf. 15 490	TO 500 Réf. 15 457	TO 502 Réf. 15 458	TO 503 Réf. 15 555	TO 600 Réf. 15 673
22	 Ø8x20 - 121 110	-	2	2	2	6	2	4	6
23	 Ø6x45 - 121 011	-	2	2	2	10	2	8	10
24	 Ø6x35 - 121 008	-	-	-	-	4	-	4	4
25	 Ø6x55 - 121 013	-	4	4	4	4	4	-	4
26	 Ø8x50 - 121 021	-	-	-	-	4	-	4	4
27	 Ø8x100 - 121 134	8	8	8	8	8	8	8	8
28	 Ø8x120 - 121 135	2	3	3	3	5	3	4	5
29	 Ø8x70 - 121 202	-	2	2	2	2	2	-	2
30	 Ø8x55 - 121 209	-	2	2	2	6	2	4	6
31	 Ø8x60 - 121 311	8	8	8	8	8	8	8	8
32	 Ø8 - 121 505	10	11	11	11	13	11	12	13
33	 Ø12 - 121 530	5	4	4	3	2	4	5	4
34	 Ø6 - 121 511	-	6	6	6	18	6	12	18
35	 Ø8 - 121 512	10	17	17	17	21	17	21	31
36	 Ø8 - 121 603	28	35	35	35	53	35	46	53
37	 Ø8 - 121 609	-	2	2	2	6	2	4	6
38	 Ø6 - 121 602	-	6	6	6	18	6	12	18
39	 ØLL8 - 121 613	-	1	1	1	3	1	2	3
40	 Ø12 - 121 616	10	8	8	6	4	8	10	8
41	 122 506	-	4	4	4	12	4	8	12
42	 122 533	-	-	2	-	-	-	-	-
43	 122 536	2	2	2	2	6	2	4	6
44	 122 623	-	4	4	4	12	4	8	12
45	 122 539	-	-	-	-	4	-	4	4

REF.	(A)
15 345	125 213
15 455	125 215
15 460	
15 490	125 218
15 457	125 217
15 458	125 221
15 555	125 223
15 673	125 230

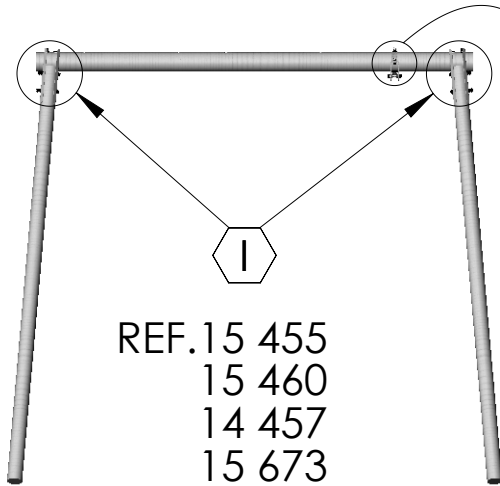

REF.15 455
15 460
14 457
15 673

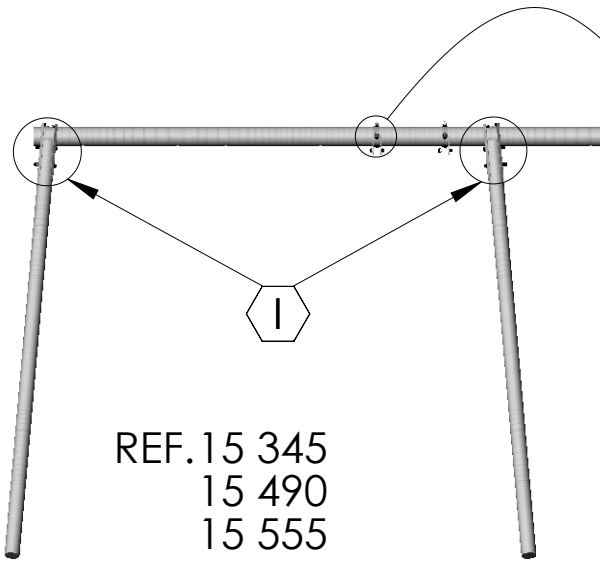

REF.15 345
15 490
15 555

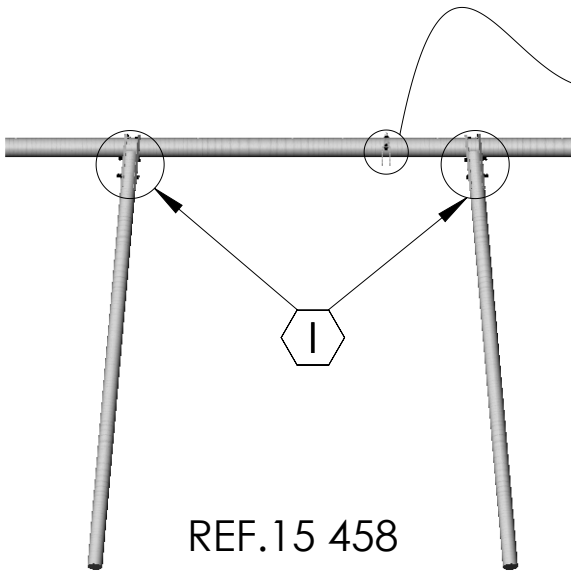

REF.15 458

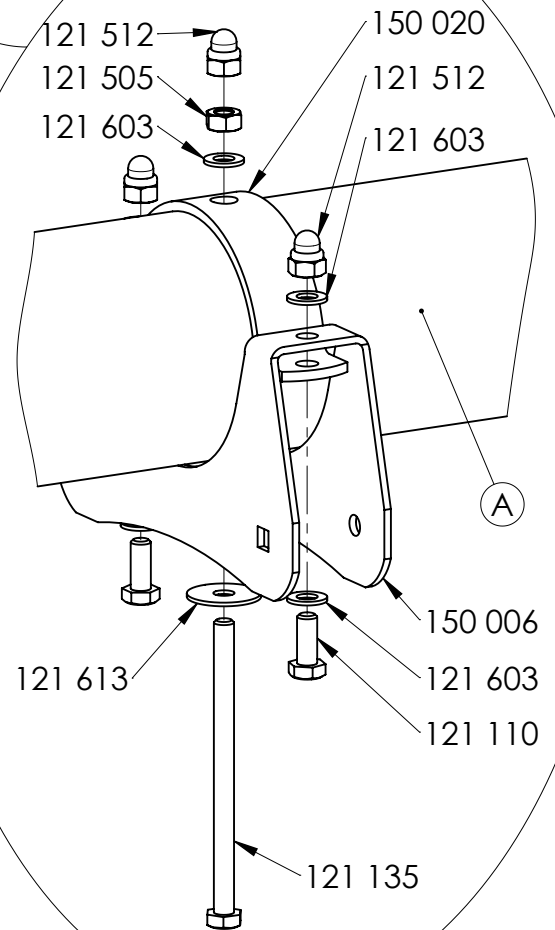

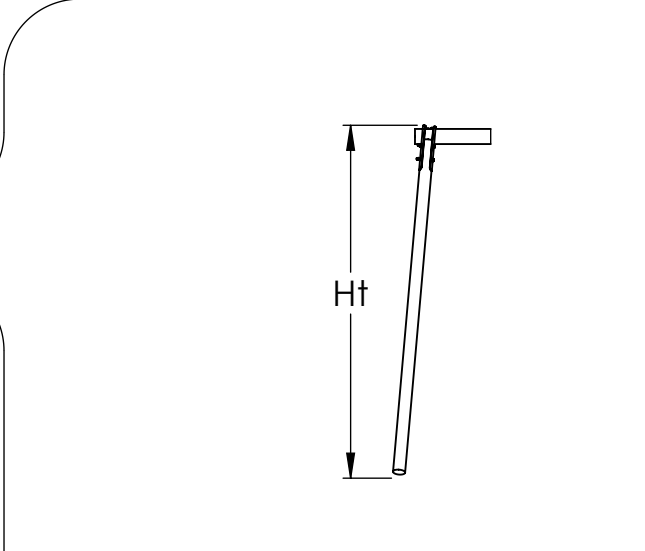
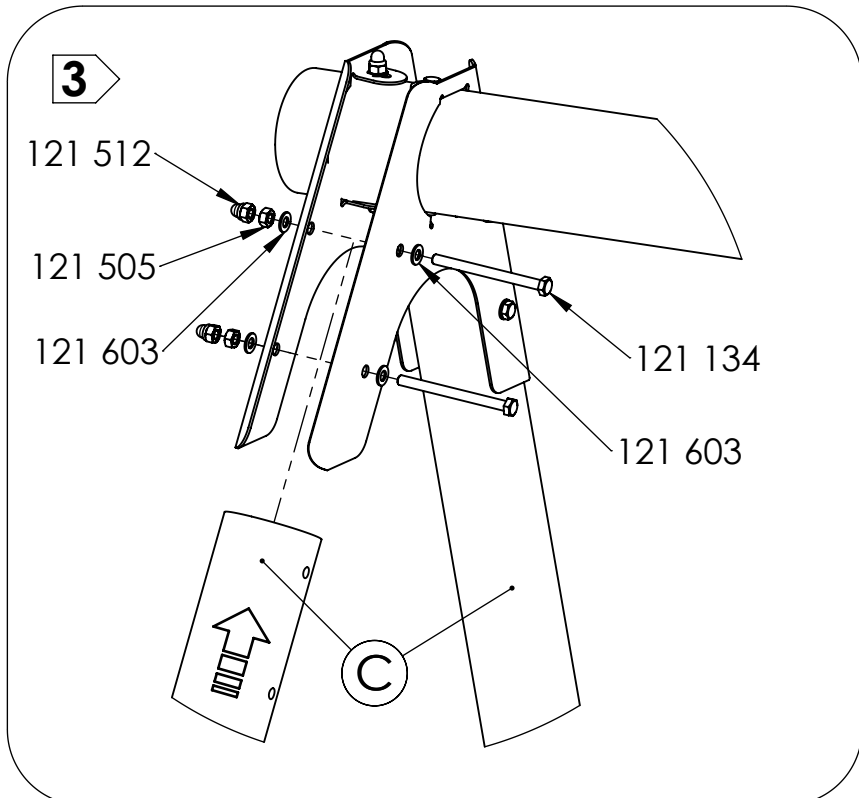
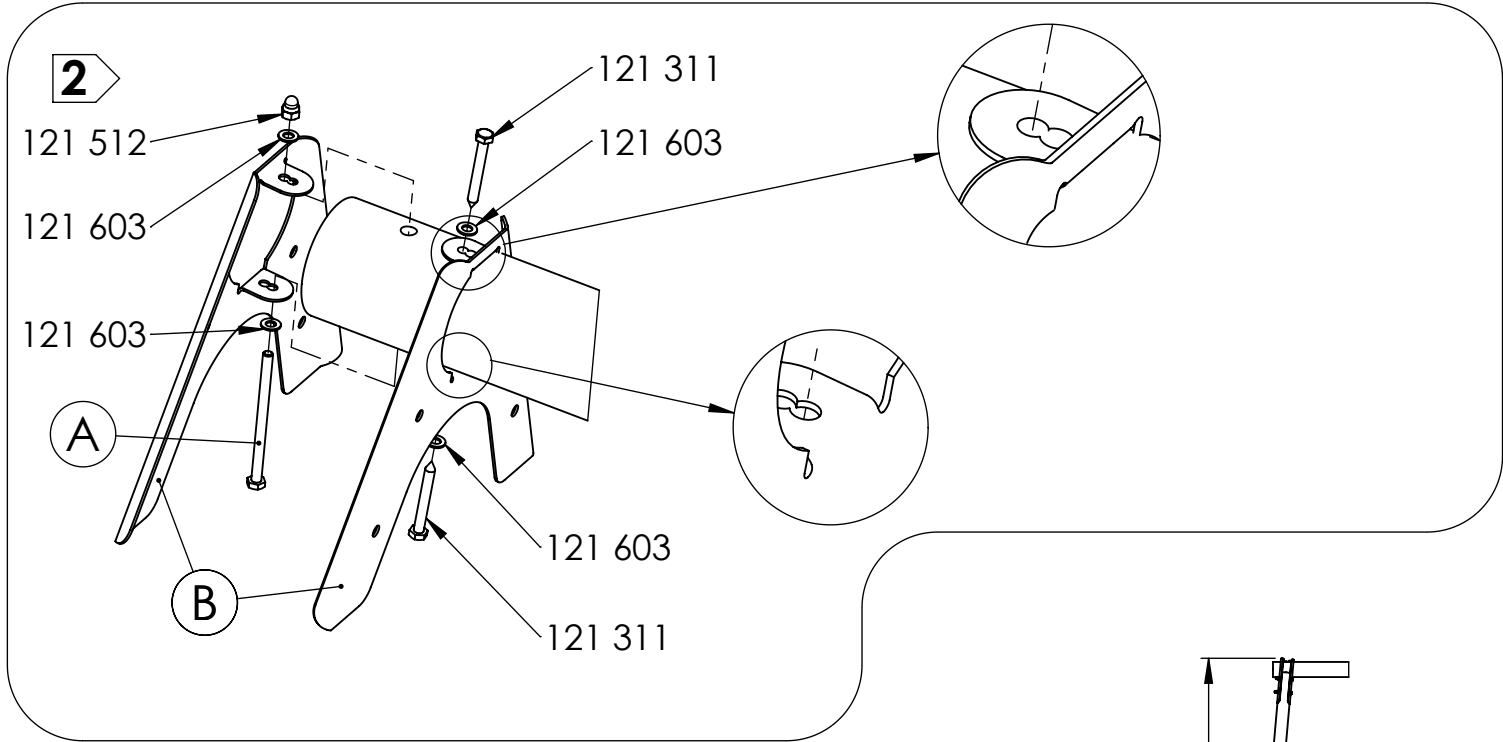
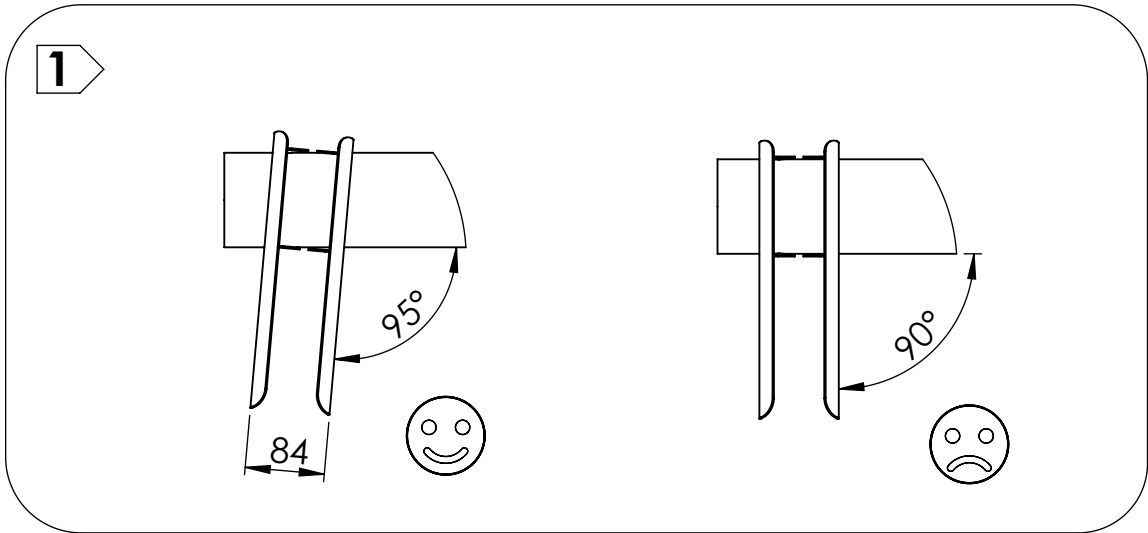
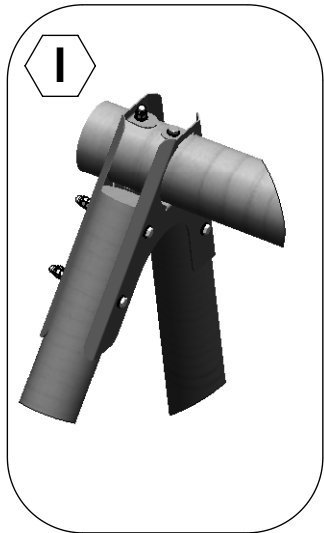

Ht	(A)	(B)	(C)
1,90 m	121 134	150 776	125 142
2,30 m	121 135	150 777	125 198
2,50 m			125 128

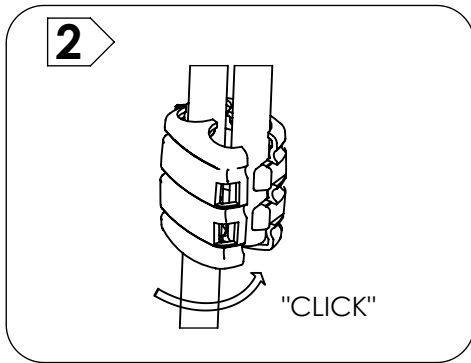

1

∅	A	B	C	D
80	122 037	121 617	121 617	121 509
100	122 035		121 616	121 530

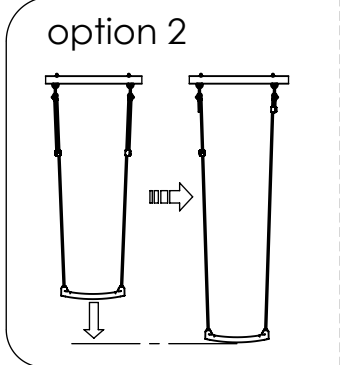
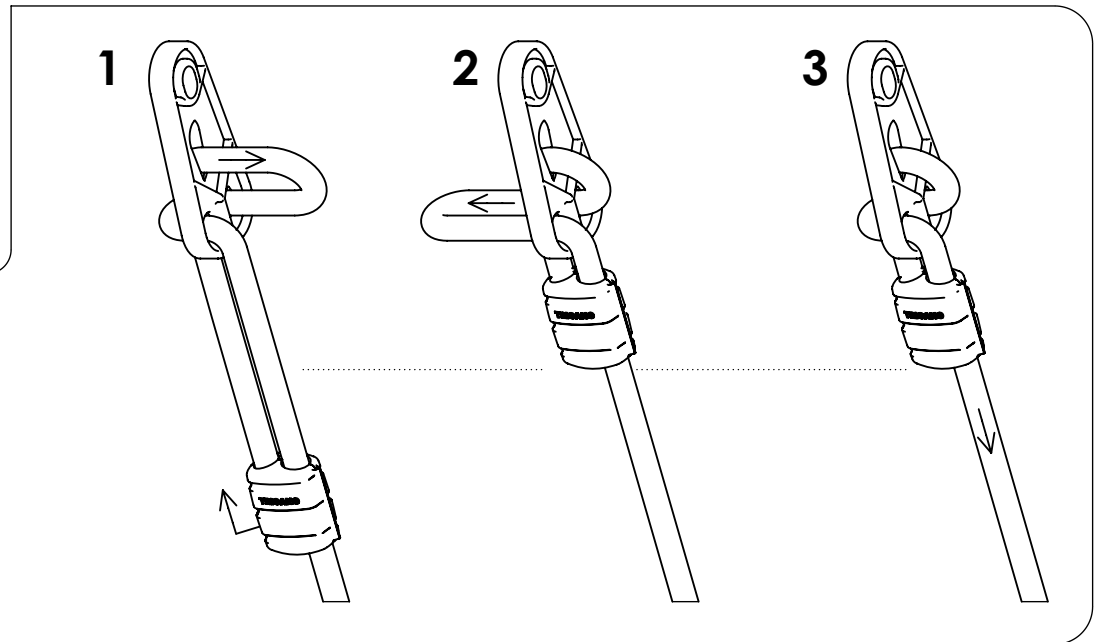
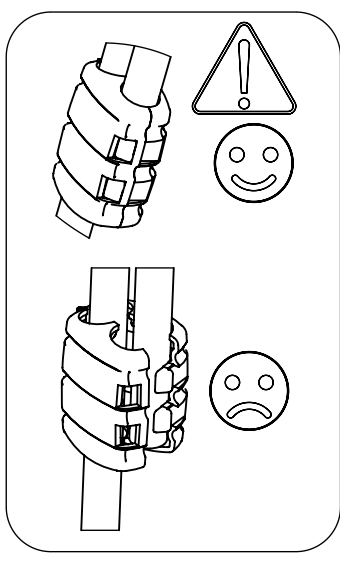
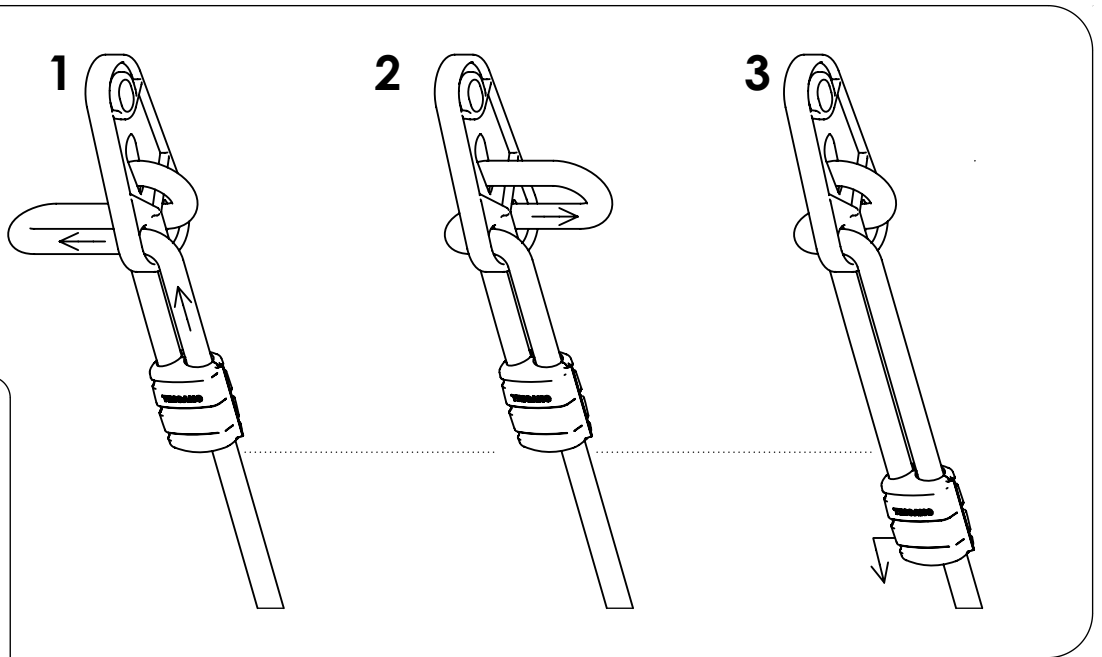
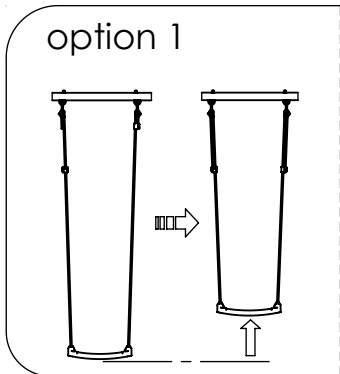

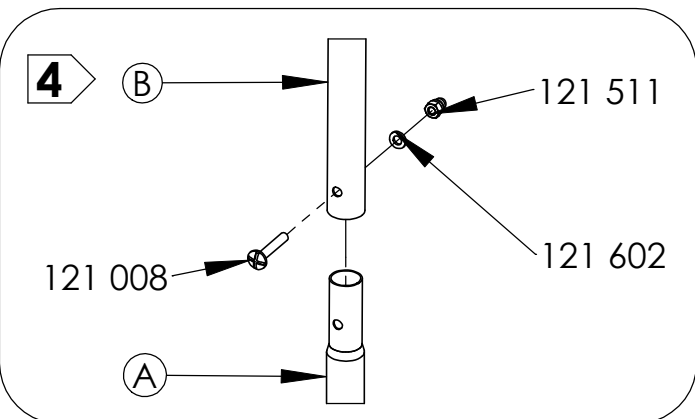
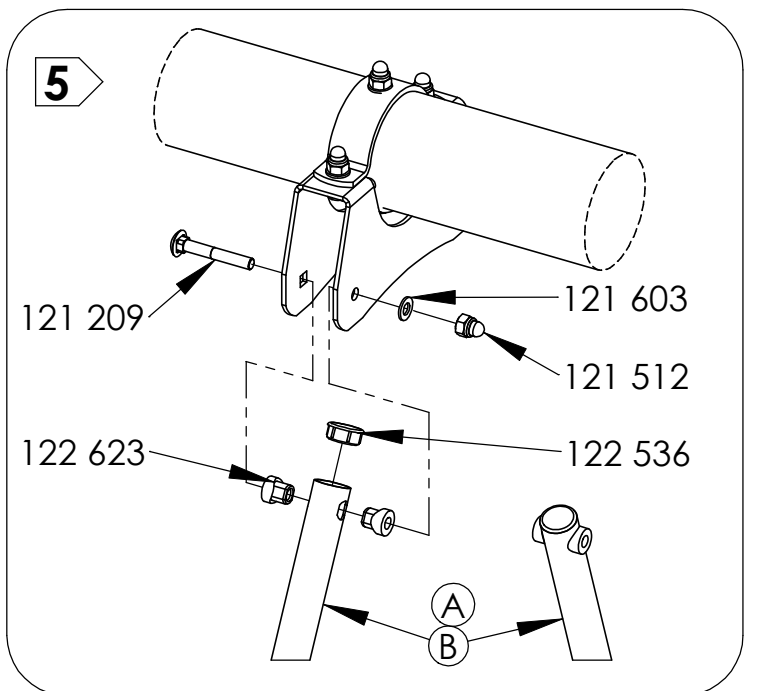
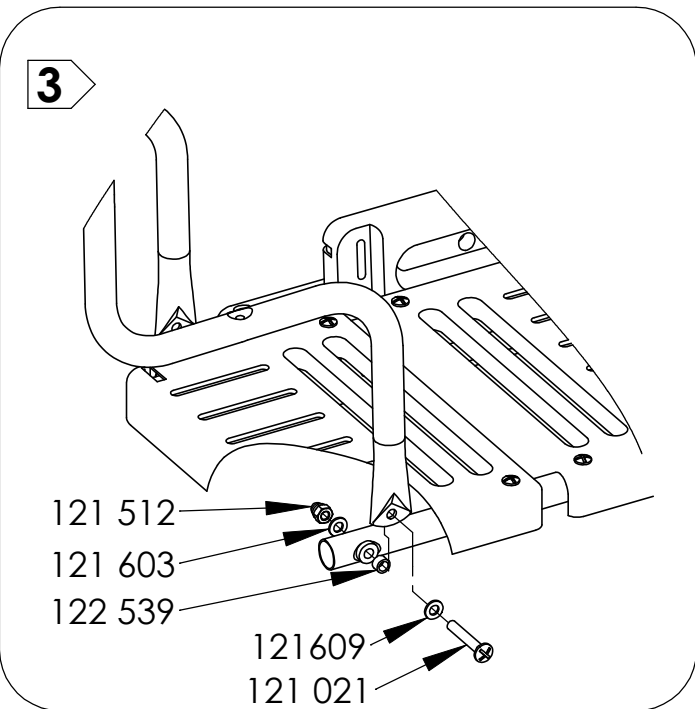
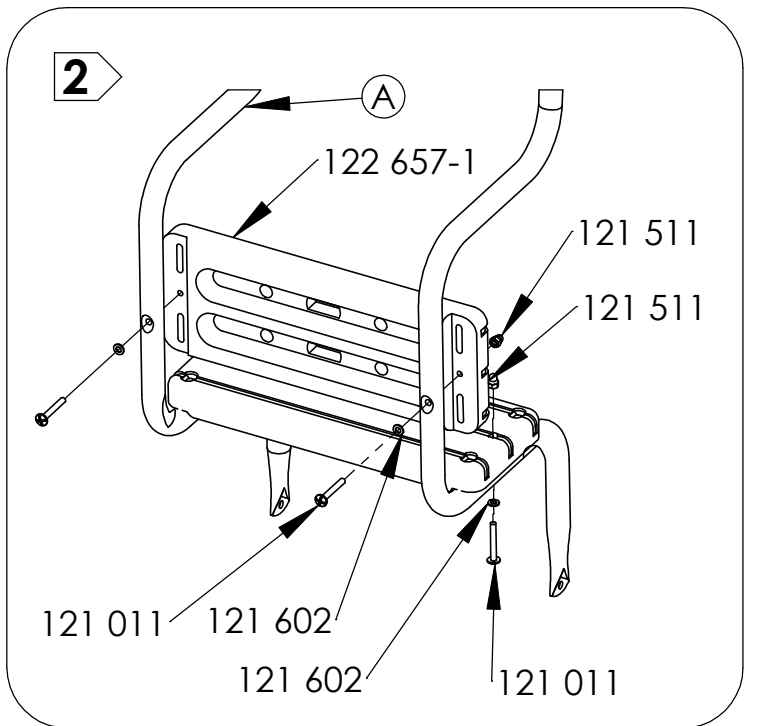
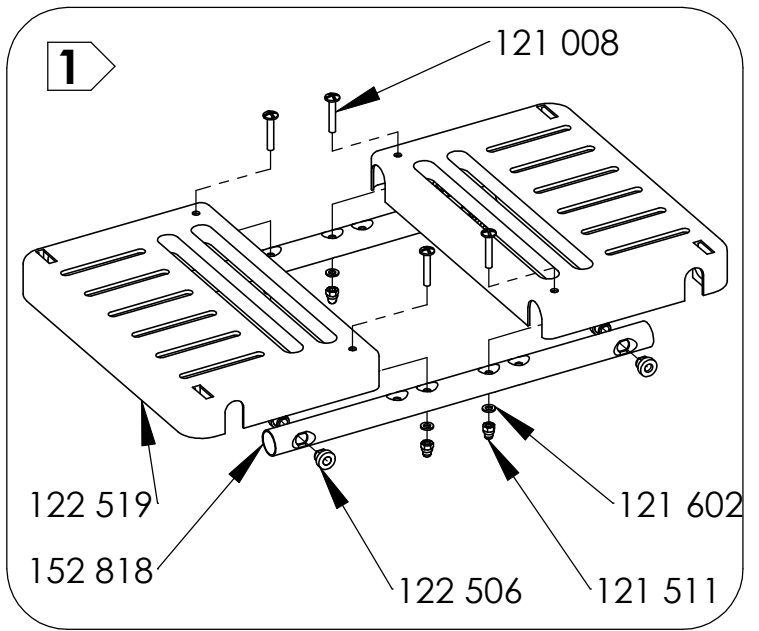
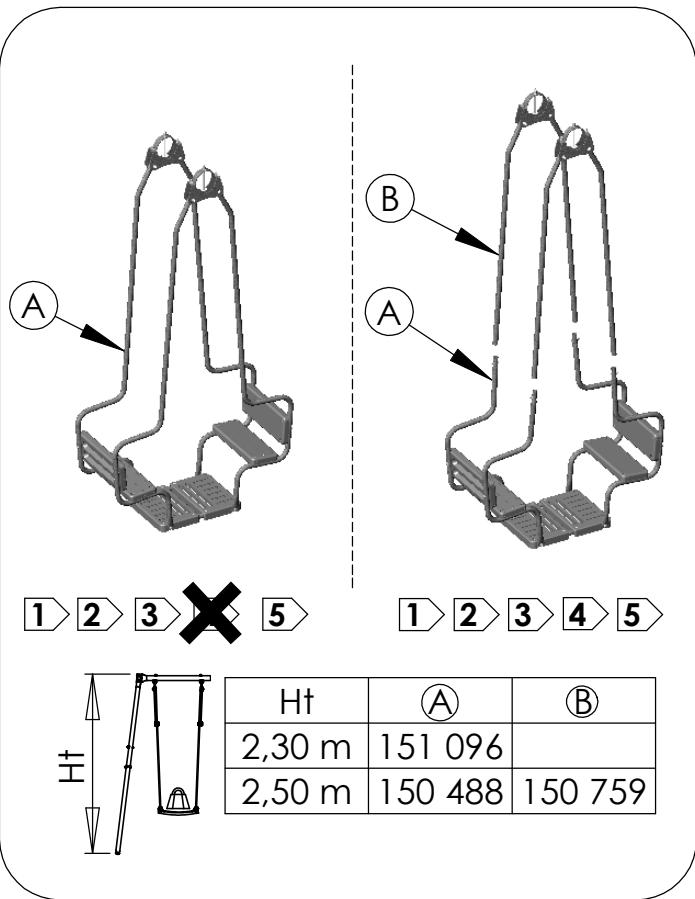

Ht	(A)	(B)
1,90 m	151 090	
2,30 m	151 117	
2,50 m	151 123	150 759

1

2

3

4

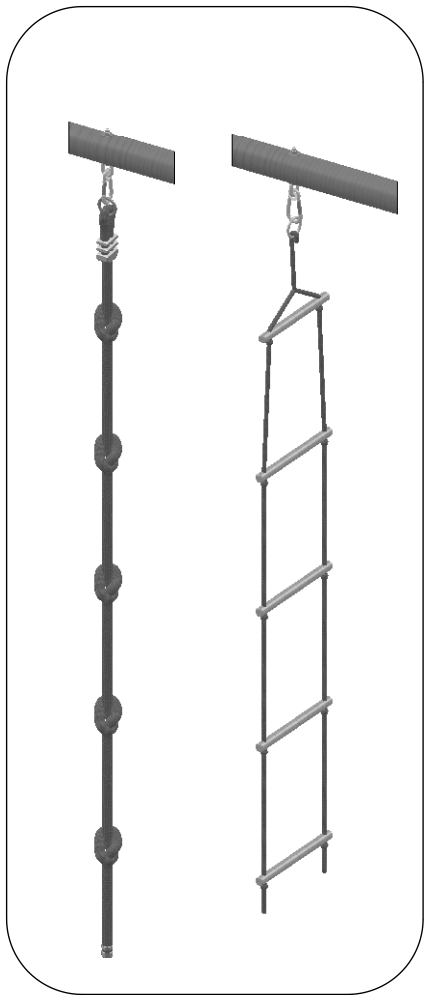

Ø	(A)	(B)	(C)	(D)
80	122 037	121 617	121 617	121 509
100	122 035		121 616	121 530

