

Notice de montage  
 Assembling instructions  
 Montage Anweisungen  
 Montaje instructie  
 Noticia de montagen  
 Istruzioni per il montaggio  
 Instruções de montagem

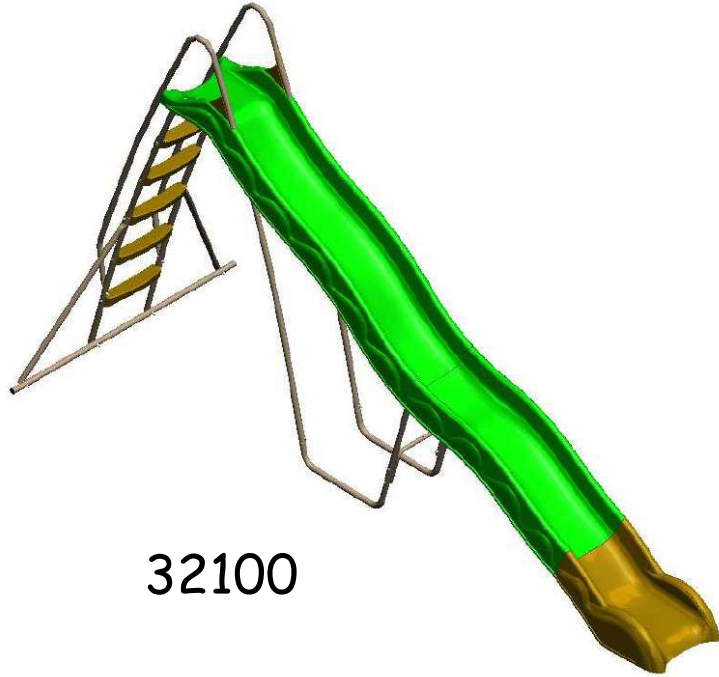

32100

## Toboggan Double vague

TRIGANO JARDIN  
 Usine du Boulay  
 41310 – Cormenon, France

- F** A LIRE IMPERATIVEMENT AVANT DE COMMENCER LE MONTAGE DE VOTRE PRODUIT - SCHELLEMENT BETON IMPERATIF
- UK** IT IS ESSENTIAL TO READ THE MANUAL BEFORE STARTING TO ASSEMBLY YOUR PRODUCT - MUST BE FIXED IN CONCRETE
- D** VOR DER MONTAGE DES ARTIKELS UNBEDINGT DURCHLESEN - MUSS UNBEDINGT EINBETONIERT WERDEN
- NL** LEES DIT VERPLICHT EN GRONDIG DOOR VOORDAT U UW TOESTEL GAAT MONTEREN - HET IS NOODZAKELIJK TE BEVESTIGEN MET GRONDANKERS
- I** LEGGERE ATTENTAMENTE PRIMA DI INIZIARE IL MONTAGGIO DEL PRODOTTO - O CHUMBAMENTO É IMPERATIVO
- SP** DE LECTURA IMPRESINDIBLE ANTES DE EMPEZAR CON EL MONTAJE DEL PRODUCTO - ESSERE FISSATO SALDAMENTE NEL CEMENTO
- P** A LER IMPERATIVAMENTE ANTES DE COMEÇAR A MONTAGEM DO SEU PRODUTO - EMPOTRAMIENTO IMPERATIVO

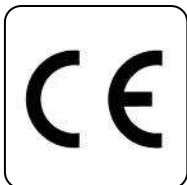
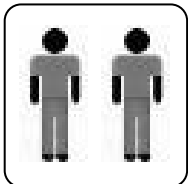

- F** Veuillez garder impérativement la notice de montage qui vous sera utile pour l'entretien de votre produit.
- UK** It is imperative that you keep the assembling instructions, which be of use for product maintenance.
- D** Bewahren Sie unbedingt die Montageanleitung auf, die Sie zur Wartung und Pflege Ihres Artikels brauchen.
- NL** Bewaar de gebruiksaanwijzing zorgvuldig, deze zal nuttig zijn voor het onderhoud van uw produkt.
- I** Guarde imperativamente as intruções de montagem, que serão úteis para a manutenção do seu produto.
- SP** Conservare il manuale di montaggio per le ulteriori operazioni di manutenzione.
- P** Conserve cuidadosamente las intrucciones de montage, ya que le servirán para el mantenimiento de su producto.

- F** Zone de sécurité: 2,00 m.  
 - aucun objet en appui sur le produit  
 - Recouvrir le béton de 5 cm de terre meuble
- UK** Safety area: 2,00 m.  
 - No object around the product  
 - Cover the concrete dies with a 5cm layer of soil
- D** Sicherheitsbereich: 2,00 m.  
 - Kein Gegenstände in der Nähe der Rutsche belassen  
 - 5cm Rasenüberdeckung erforderlich im Leiterbereich und im Auslaufbereich
- NL** Veiligheidszone: 2,00 m.  
 - Geen enkel voorwerp rondom het toestel  
 - Bedek de betonblokken met 5cm losse aarde
- I** Zona di sicurezza: 2,00 m.  
 - Nessun oggetto intorno al prodotto  
 - Ricoprire i dadi in cemento di 5cm terra mobile
- SP** Area de seguridad: 2,00 m.  
 - Ningún objeto alrededor del producto  
 - Recubrir el hormigón con 5cm de tierra blanda
- P** Zona de segurança: 2,00 m.  
 - Nenhum objecto em redor do produto  
 - Abranger o betão de 5cm de terra móvel.

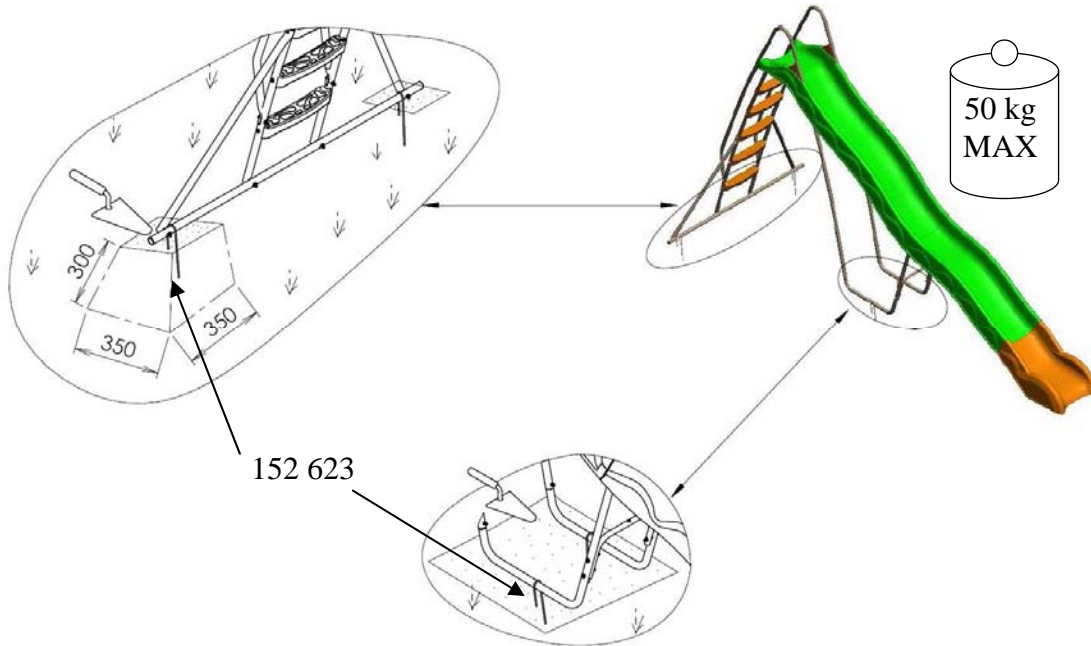
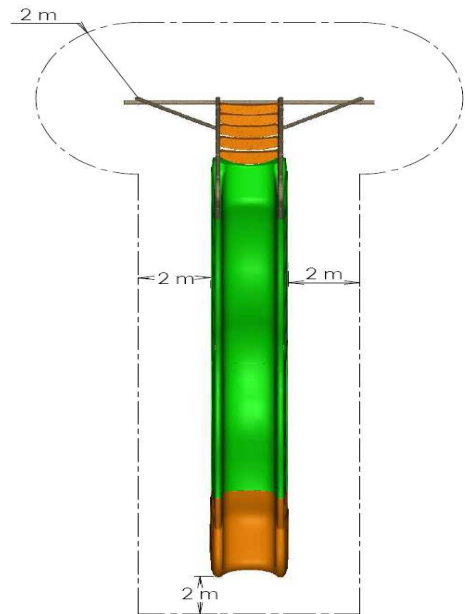

F – Procéder à l'assemblage des pièces avec la visserie, **sans serrer**. Une fois assemblé entièrement, serrer définitivement toutes les vis. Ensuite, sceller **impérativement** votre toboggan.

GB – Use the screws to assemble the pieces but without **tightening them**. Once entirely assembled tighten all the screws definitively. It is then **essential** to firmly anchor your slide.











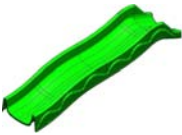
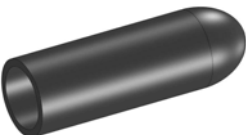

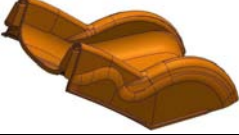



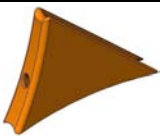





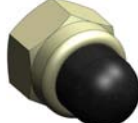

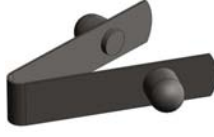

DE – Die Einzerteile mit Hilfe der Schrauben zusammenbauen, dabei die Schrauben **erst nur lose anziehen**. Sobald alles zusammengabaut wurde, alle Schrauben festziehen. Anschließend muss das Rutsche **unbedingt** fest verankert werden.

NL – Ga verder mt het samenstellen, stuk per stuk, door gebruik te maken van de schroeven, **zonder deze aan te draaien**. Wanneer alles gemonteerd is, kunt u de schroeven complete aandraaien. Maak hierna uw glijbanen heel steig hast.

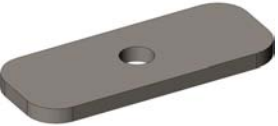
ES – Proceda a ensamblar las piezas con tornillos y pernos, **sin ajustar**. Una vez que haya realizado el ensamblado completo, ajuste definitivamente todos los tornillos. A continuación, es **obligatorio** que selle el toboganes.

IT – Procedere all'assemblaggio dei pezzi con viti e bulloni, **senza stringere**. Una volta completato l'assemblaggio, stringere definitivamente tutte le viti. In seguito, sigillare **obbligatoriamente** el scivoli.

PO – Procederà montagem das peças com os parafusos, **sem apertar**. Um avez montado completamente apertar definitivamente todo os parafusos. Em seguida, fixar **imperativamente** o seu escorrega.

Réf., Rif., Art., Nr., Ref.			
Quantité, quantità, anzahl, quantity, aantal, cantidad, quantidade			
	122 812	<b>32100</b> x 1	
			<b>32100</b> x 2
	122 813	x 1	
			6x45 121 011 x 4
	122 814	x 1	
			6x55 121 013 x 8
	122 816	x 5	
			6x40 121 010 x 16
	122 821	x 2	
			6x15 121 101 x 2
	151 013 17	x 2	
			4.8x38 121 376 x 2
	151 011 17	x 2	
			6x20 121 100 x 12
	151 012 17	x 2	
			M6 121 511 x 42
	151 010 17	x 1	
			Ø6 121 602 x 54
	151 039 17	x 2	
			Ø6 121 611 x 2
	151 040 17	x 1	
			122 104 x 2
	151 042 17	x 2	
			151 041 x 2
	Ø30 122 532	x2	
			Ø30 122 671 x 2
	Ø6.2 122 679	x 2	
			152 623 x 4
			
			M6 121 504 x 2

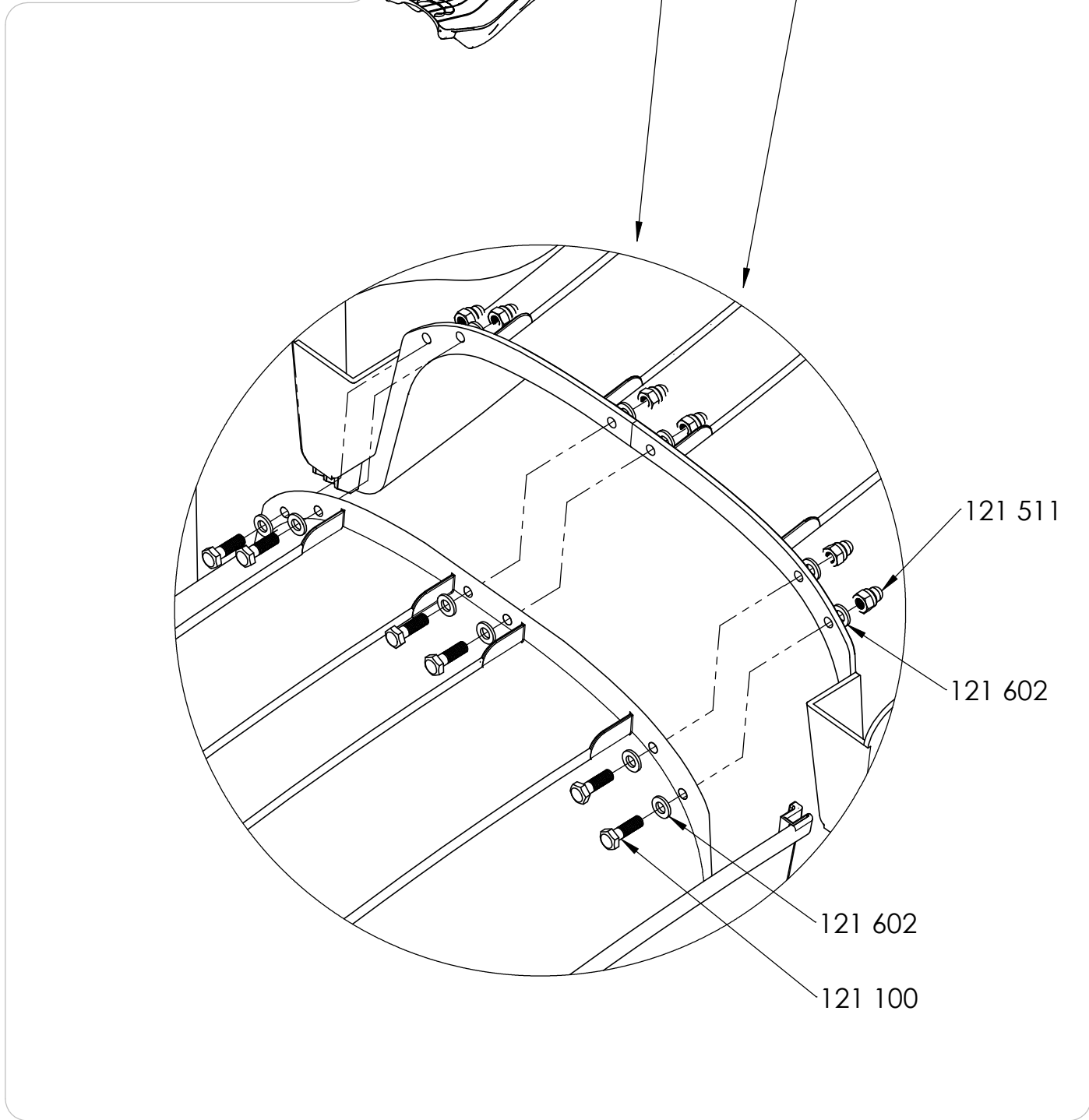
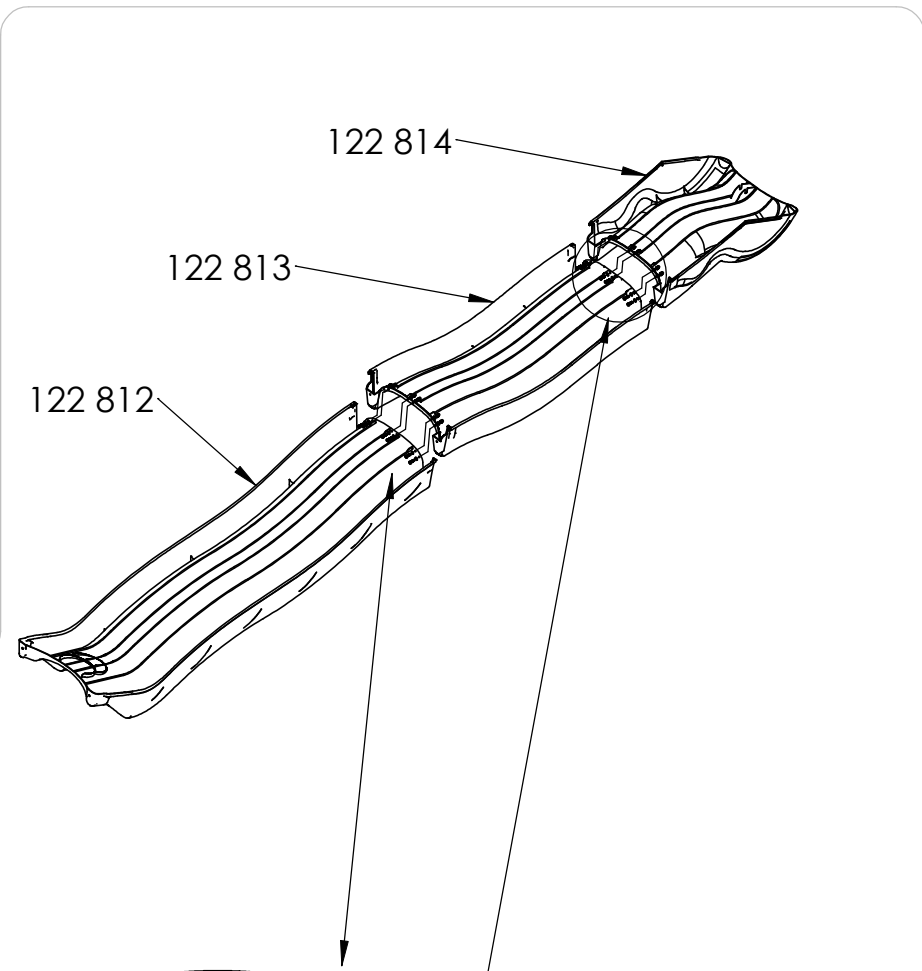
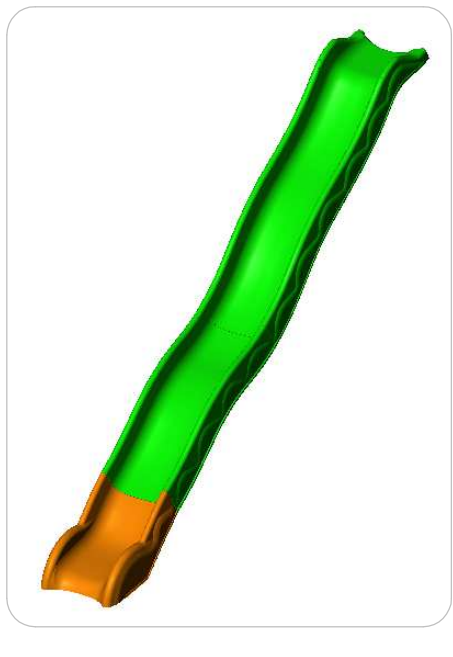

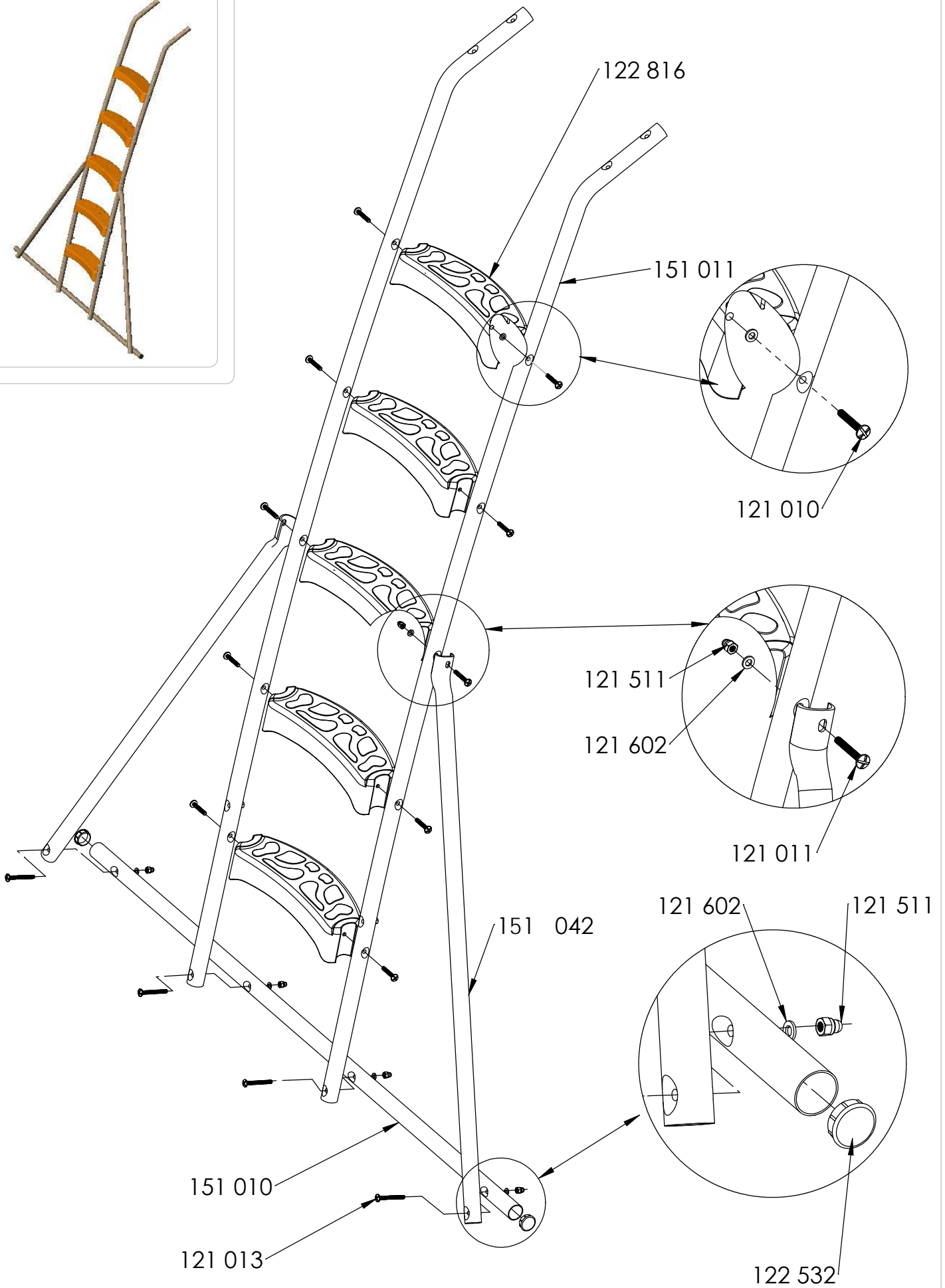

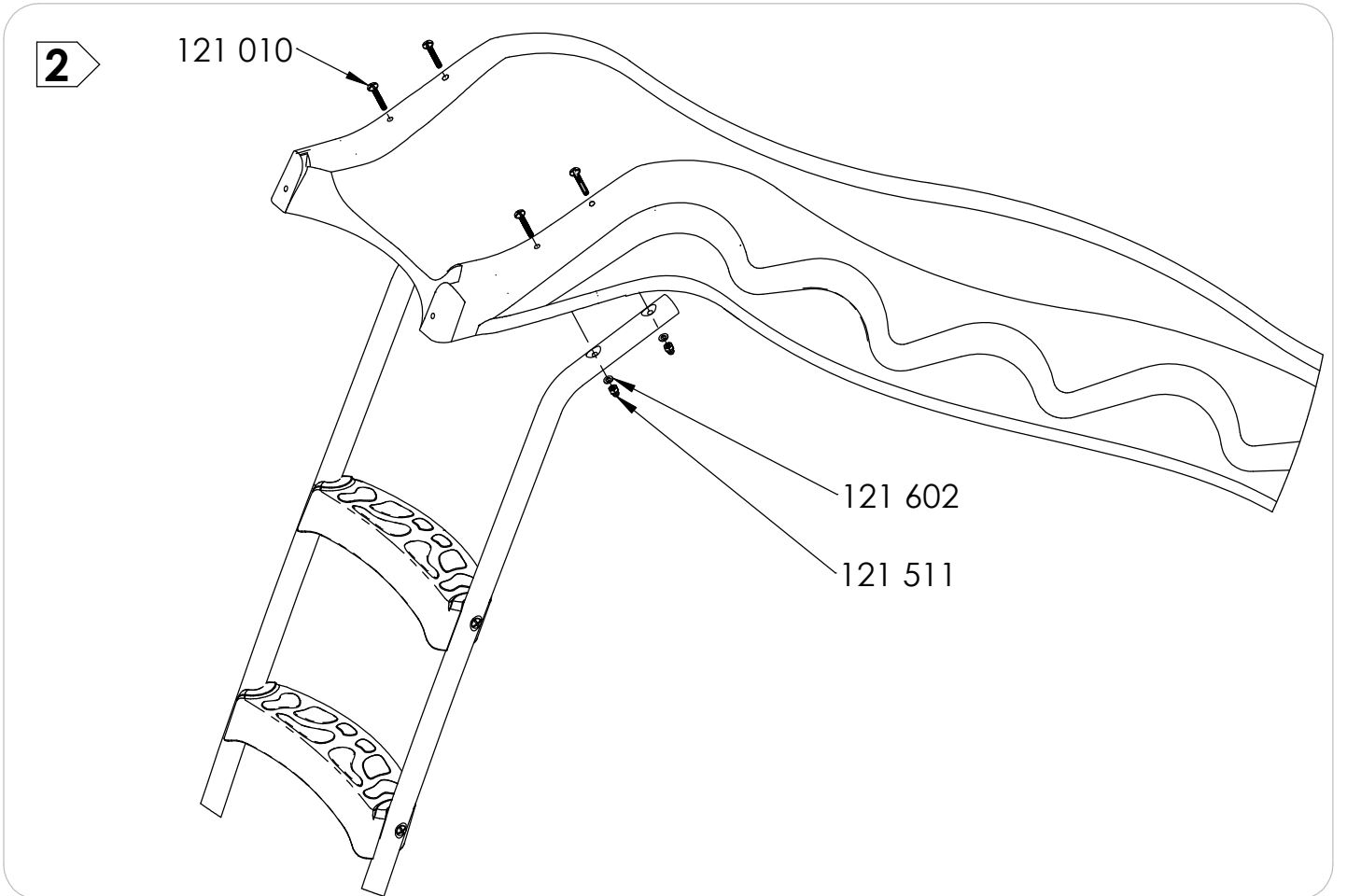
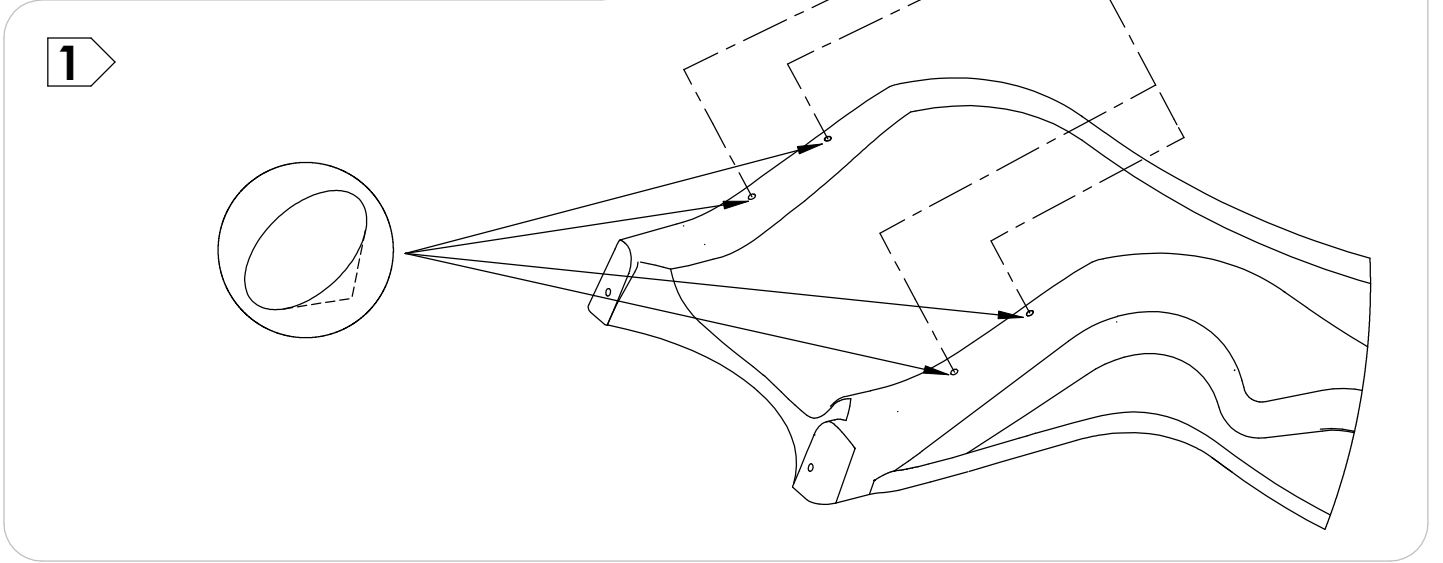
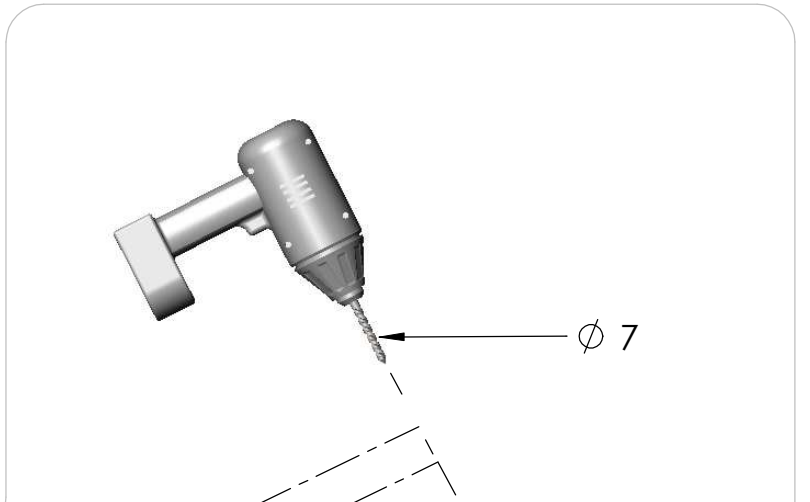

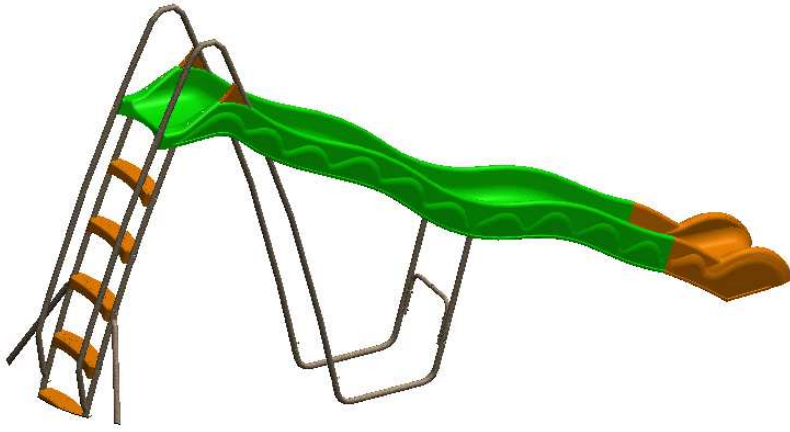

1

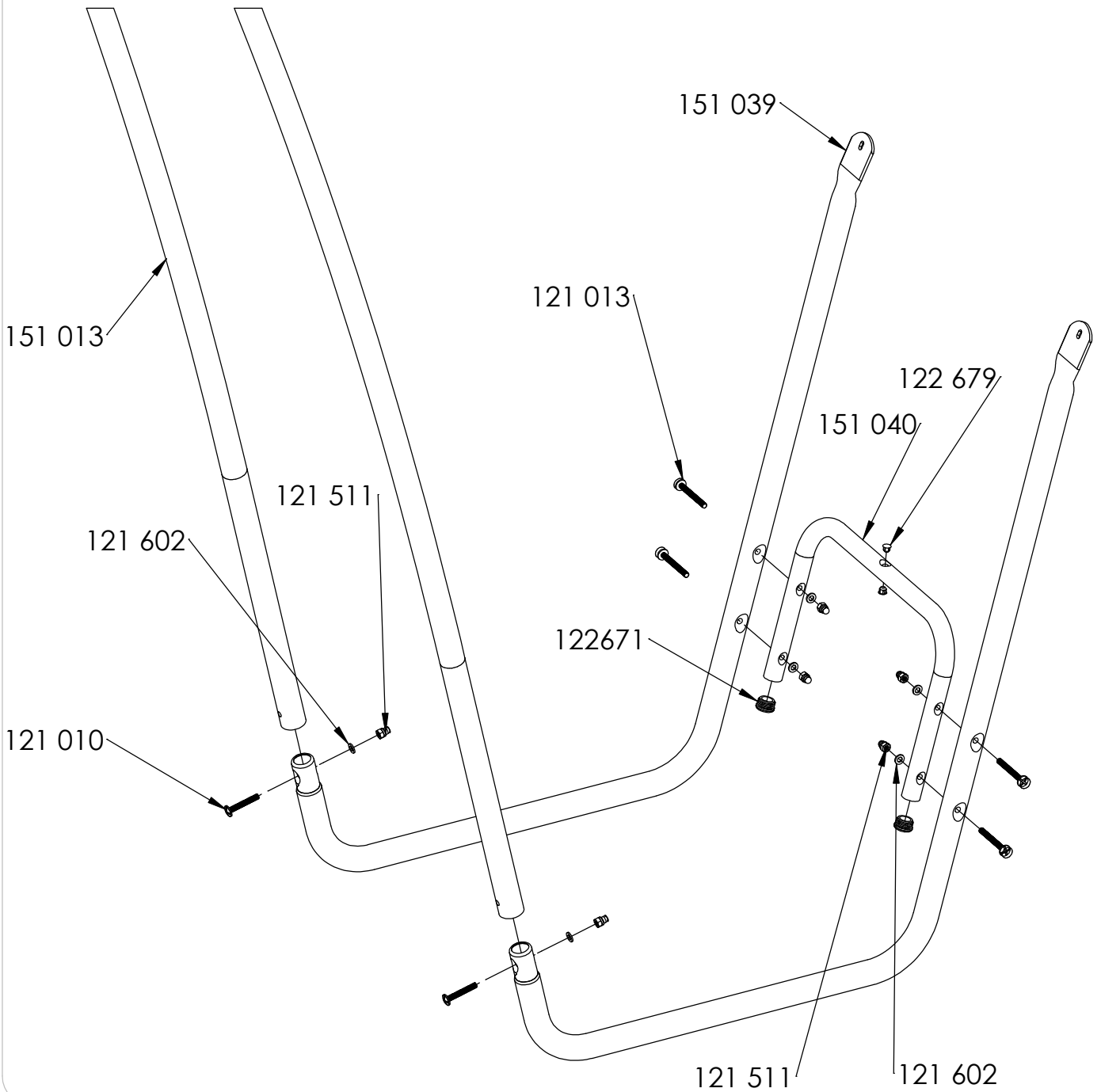

2

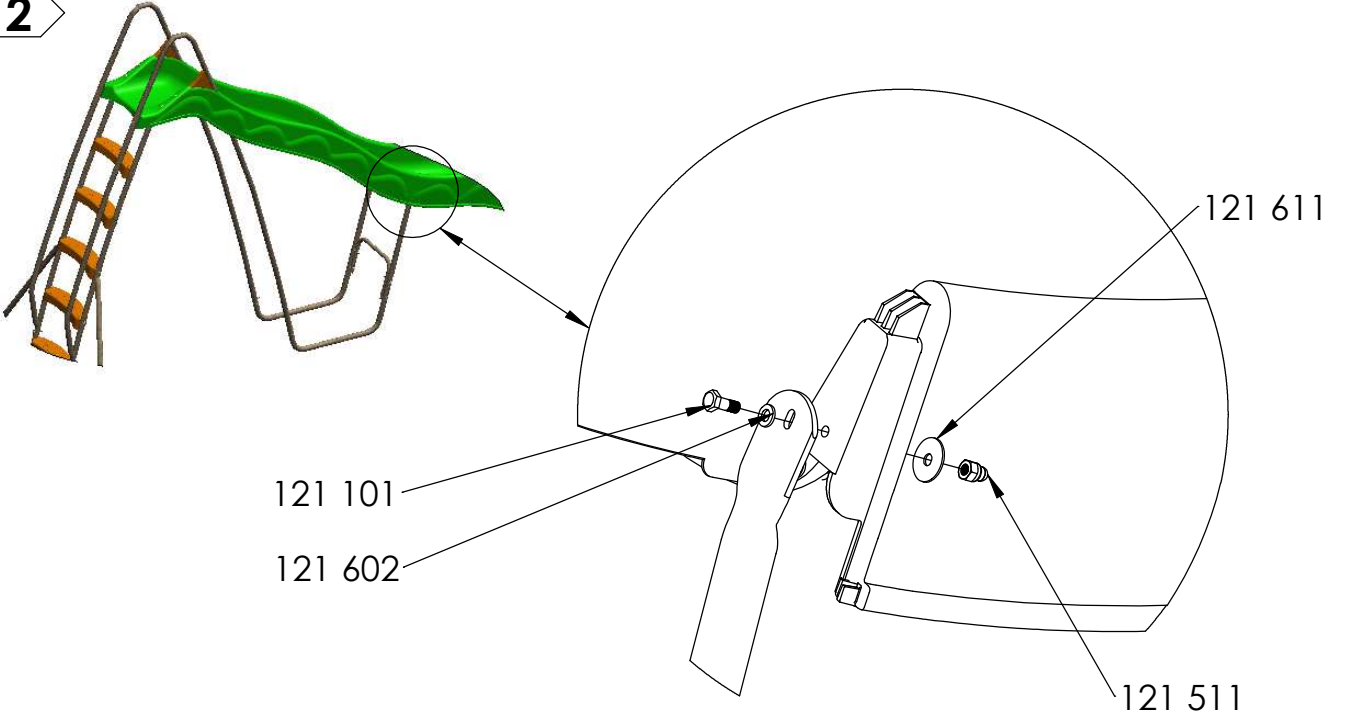

3

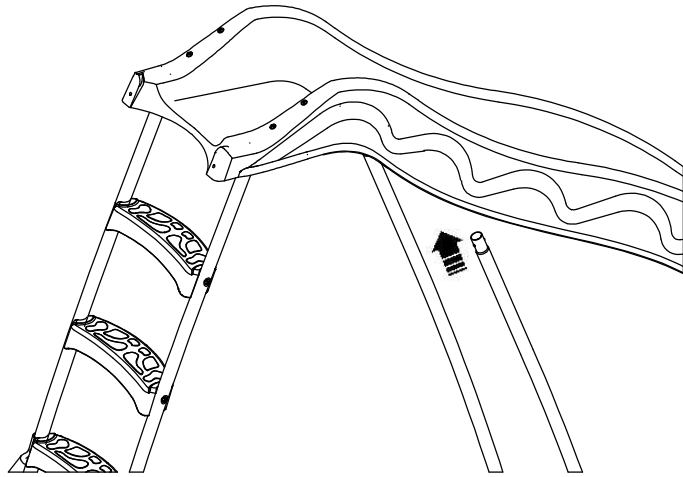

4

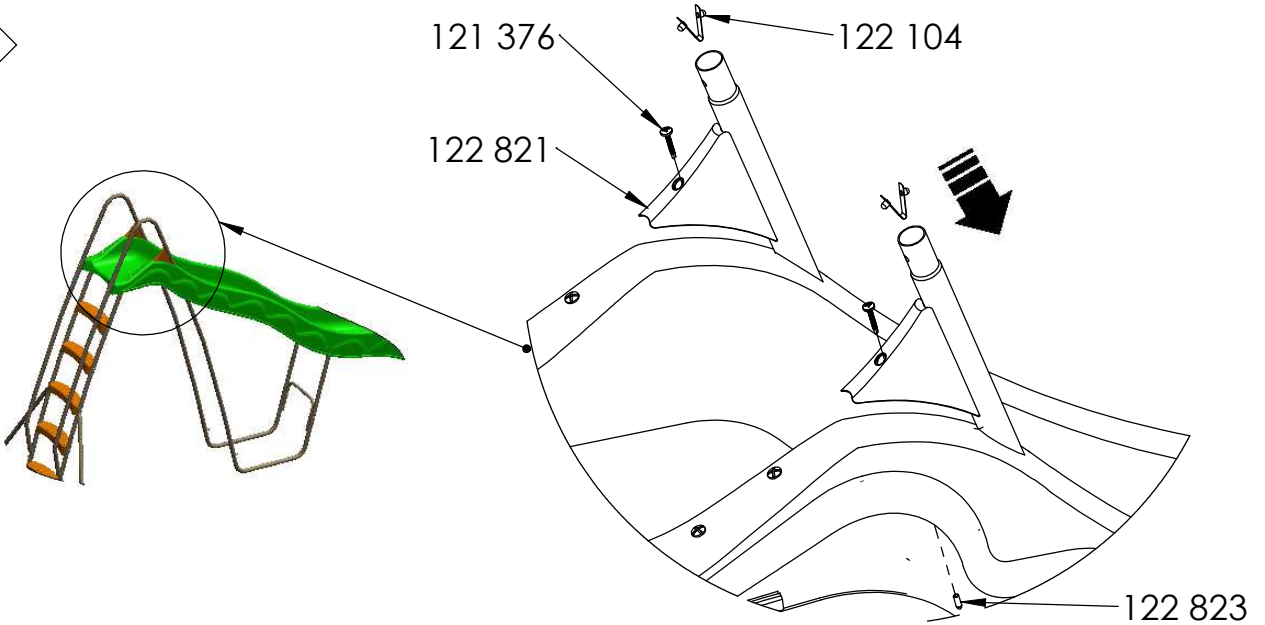

5

