



TRIGANO JARDIN

USINE DU BOULAY
41170 - CORMENON
FRANCE

NOTICE DE MONTAGE
ASSEMBLING INSTRUCTIONS
MONTAGE ANSWEISUNGEN
MONTAJE INSTRUCTIE
NOTICIA DE MONTAGEN
ISTRUZIONI PER IL MONTAGGIO
INSTRUCCIONES DE MONTAJE

N° 123493-4
Rev B

R : 7486-1

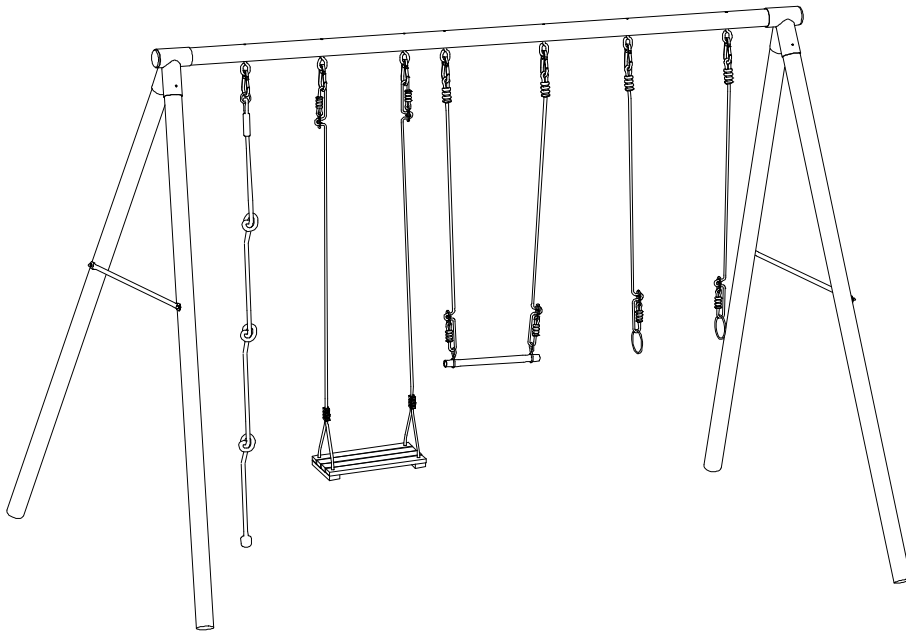

NOUS VOUS PRÉCISONS QUE LE BOIS EST UN PRODUIT NATUREL QUI RÉAGIT AUX VARIATIONS DE TEMPÉRATURE ET D'HUMIDITÉ. DES FISSURES ET DES FENTES PEUVENT APPARAÎTRE. C'EST TOUT À FAIT NORMAL ET CELA N'AFECTE EN RIEN LA SOLIDITÉ, LA DURÉE DE VIE OU LA GARANTIE DE CE PRODUIT.

PLEASE BE AWARE, WOOD IS A NATURAL PRODUCT THAT RE-ACTS TO TEMPERATURE AND HUMIDITY VARIATIONS. SPLITS AND CRACKS WILL OCCUR. THIS IS COMPLETELY NORMAL AND DOES NOT AFFECT THE INTEGRITY OF YOUR PRODUCT OR YOUR WARRANTY.

WIR ERINNERN IHNEN, DASS DAS HOLZ NATÜRLICH IST. ES KANN SEIN, DASS EINIGE RITZE WEGEN FEUCHTIGKEITSVERÄNDERUNGEN ERSCHEINEN. DAS IST GANZ NORMAL UND DAS VERSCHLECHTERT ÜBERHAUPT NICHT DIE FESTIGKEIT, LEBENSDAUER ODER DIE GARANTIE DIESES PRODUKTS.

WIJ WIJZEN ER OP DAT HOUT EEN NATUURLIJK PRODUCT IS DAT REAGEERT OP TEMPERATUUR-EN VOCHTIGHEIDSVERSCHILLEN. ER KUNNEN SCHEURTJES EN GLEUVEN OPTREDEN. DIT IS NORMAAL EN DOET NIETS AF AAN DE DEGELIJKHEID, DE LEVENSDUUR OF DE GARANTIE VAN DIT PRODUCT.

INDICAMOS-IHE QUE A MADEIRA É UM PRODUTO NATURAL QUE REAGE ÀS VARIAÇÕES DE TEMPERATURA E DE HUMIDADE. RACHAS E FENDAS PODEM APARECER. É NORMAL E ISSO NÃO AFECTA EM NADA A SOLIDEZ, A DURAÇÃO DE VIDA OU A GARANTIA DESTE PRODUTO.

PRECISIAMO CHE IL LEGNO È UN PRODOTTO NATURALE CHE REAGISCE ALLE VARIAZIONI DI TEMPERATURA E DI UMIDITÀ. POSSONO APPARIRE DELLE FESSURE E DELLE CREPE. CIÒ È DEL TUTTO NORMALE E NON HA ALCUN EFFETTO SULLA SOLIDITÀ, LA DURATA DI VITA O LA GARANZIA DI QUESTO PRODOTTO.



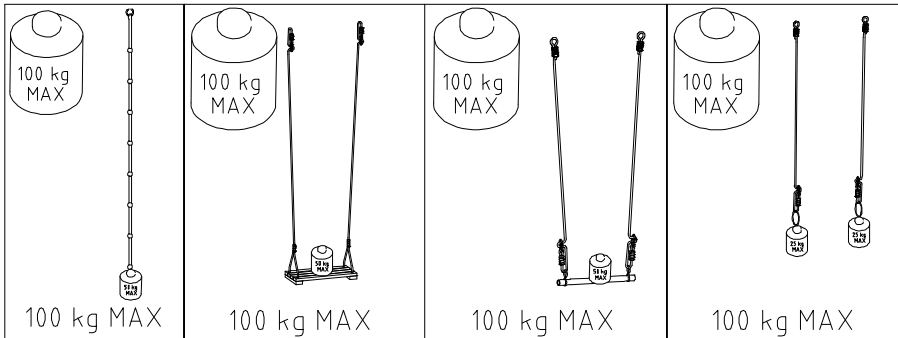



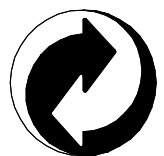
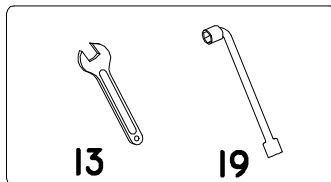
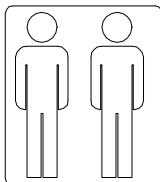
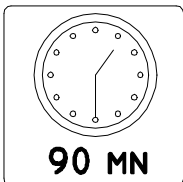





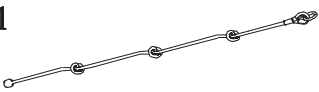

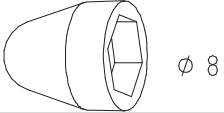
LE RECORDAMOS QUE LA MADERA ES UN PRODUCTO NATURAL QUE REACCIONA A LAS VARIACIONES DE TEMPERATURA Y HUMEDAD. PUEDEN APARECER FISURAS O GRIETAS. ES NORMAL Y NO AFECTA EN ABSOLUTO A LA SOLIDEZ, LA VIDA ÚTIL O LA GARANTÍA DEL PRODUCTO.

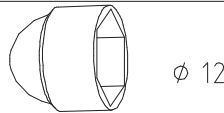

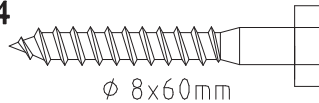
- Veuillez garder impérativement la notice de montage qui vous sera utile pour l'entretien de votre produit.
- It is imperative that you keep the assembly instructions, which be of use for product maintenance.
- Bewahren Sie unbedingt die Montageanleitung auf, die Sie zur Wartung und und Pflege Ihres Artikels brauchen.
- Bewaar de gebruiksaanwijzing zorgvuldig, deze zal nuttig zijn voor het onderhoud van uw produkt.
- Guarde imperativamente as intruções de montagem, que serão úteis para a manutenção do seu produto.
- Conservare il manuale di montaggio per le ulteriori operazioni di manutenzione.
- Conserve cuidadosamente las intrucciones de montaje, ya que le servirán para el mantenimiento de su producto.

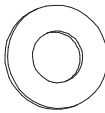
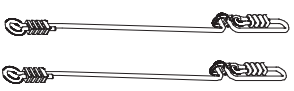

Réf., Rif., Art. Nr., Ref
 Quantité, quantità, anzahl, quantity, aantal, cantidad, quantidade

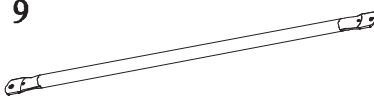
1		413072 x 4	10		420HA x 1	A
2		125 510 x 1	11		122725 x 1	N
3		488HA x 1	12		122592 x 16	
4		15045765 x 2	13		122640 x 7	
5		122035 x 7	14		121311 x 16	
6		152810 x 4	15		121530 x 7	
7		15423365 x 1	16		121616 x 7	
8		447029 x 2	17		121603 x 16	
9		15010065 x 2				

125156

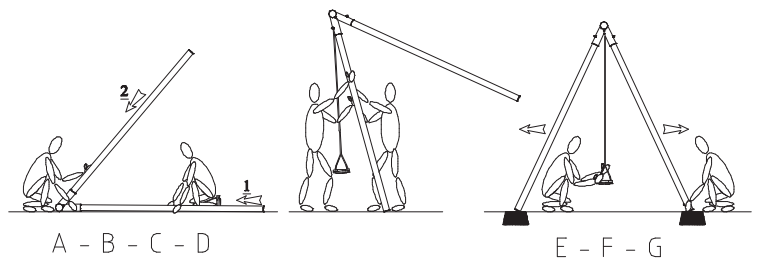
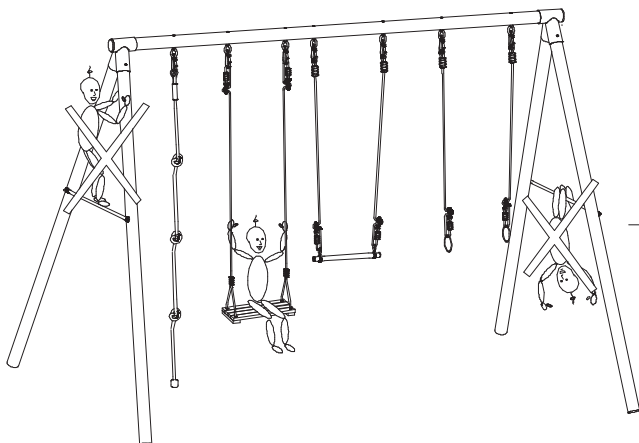
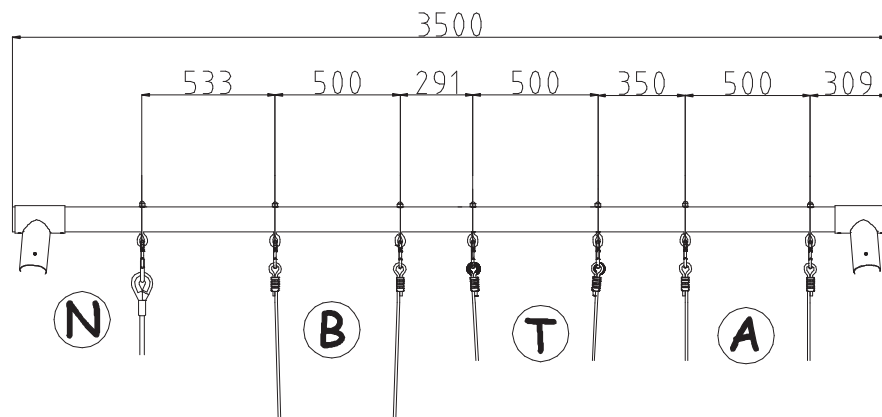

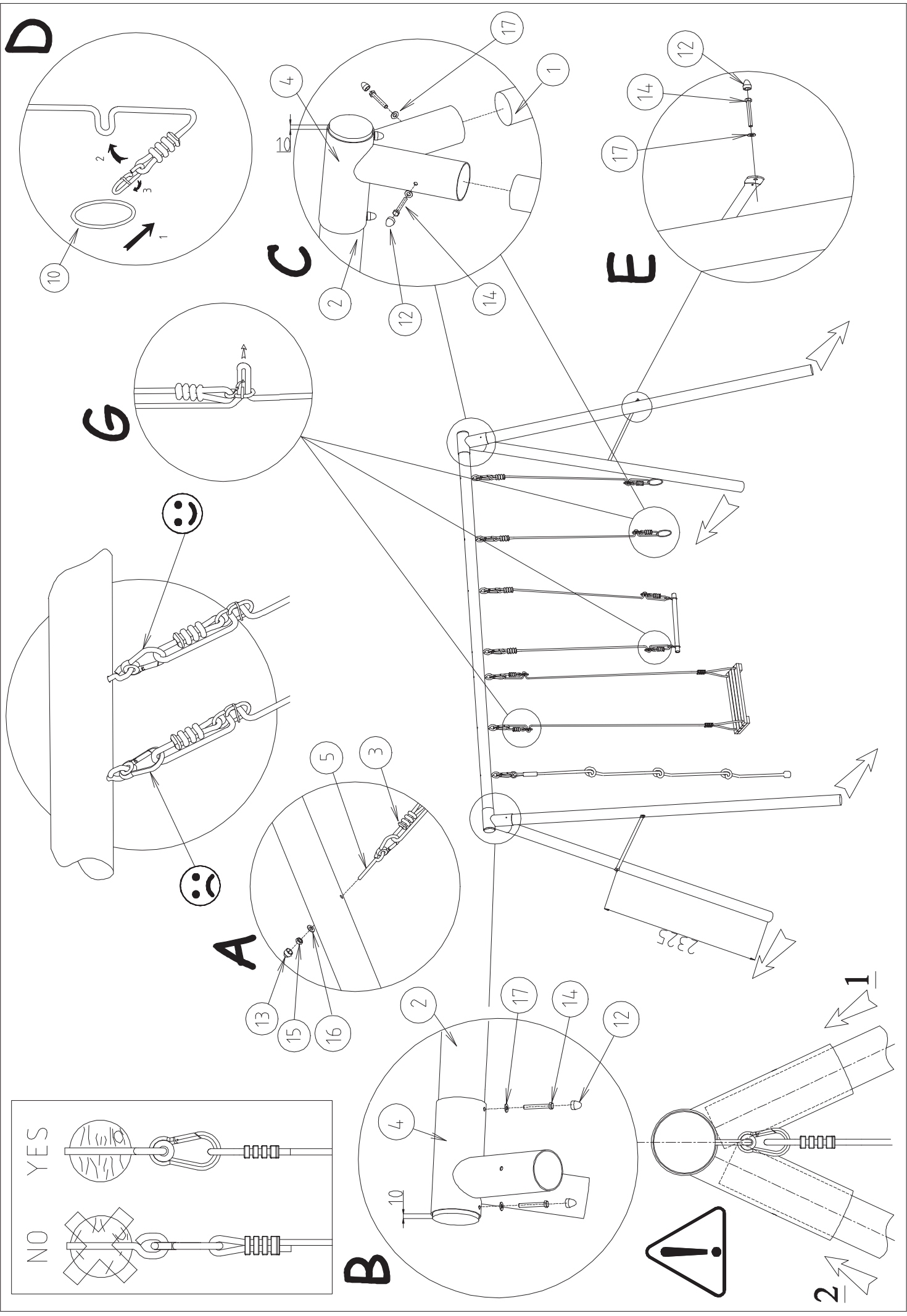

NO	
YES	

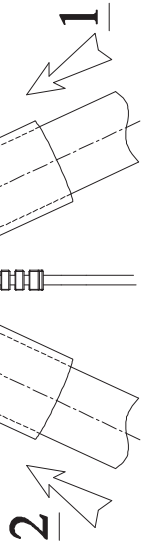

F - Zone de sécurité: 2,00m

- Aucun objet en appui sur le produit.
- Recouvrir le béton de 5cm de terre meuble.

GB - Safety area: 2,00m

- No object around the product.
- Cover the concrete dies with a 5cm layer of soil.

D - Sicherheitsbereich: 2,00m

- Keine Gegenstände in der Nähe der Rutsche belassen.
- 5cm Rasenüberdeckung erforderlich im Leiterbereich und im Auslaufbereich.

NL - Veiligheidszone: 2,00m

- Geen enkel voorwerp rondom het toestel.
- Bedek de betonblokken met 5cm losse aarde.

I - Zona di sicurezza: 2,00m

- Nessun oggetto intorno al prodotto
- Ricoprire i dadi in cemento di 5cm di terra mobile.

SP - Area de seguridad: 2,00m

- Ningún objeto alrededor del producto.
- Recubrir el hormigón con 5cm de tierra blanda.

P - Zona de segurança: 2,00m

- Nenhum objecto em redor do produto.
- Abranger o betão de 5cm de terra móvel.

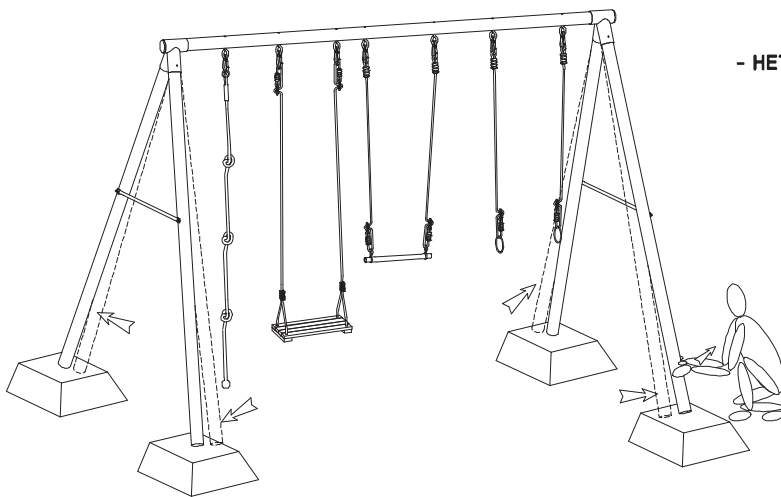
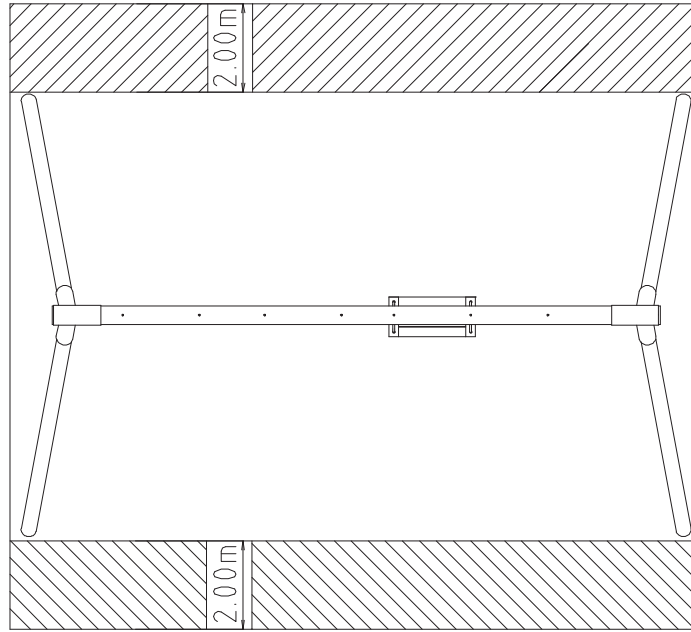

- **SCELLEMENT BETON IMPERATIF**
- **MUST BE FIXED IN CONCRETE**
- **MUSS UNBEDINGT EINBETONIERT WERDEN**
- **HET IS NOODZAKELIJK TE BEVESTIGEN MET GRONDANKERS**
- **O CHUMBAMENTO É IMPERATIVO**
- **ESSERE FISSATO SALDAMENTE NEL CEMENTO**
- **EMPOTRAMIENTO IMPERATIVO**

