

Yardmaster

INTERNATIONAL

0111

Please direct enquires to:

Yardmaster International
Cahore Road
Draperstown
BT45 7AP.
Tel: 028 796 28449

Demandes de renseignements à:

TRIGANO JARDIN
Service Commercial
Usine du Boulay
41 170 Cormenon
Mondoubleau
Tel: (02) 54 73 55 55

Bitte alle Anfragen an:

I.N.I.
Kaistraße 7-9
40221 Düsseldorf
Tel: 0211 30 21 28 15

**Assembly
Instructions**

**Instructions
D'assemblage
Abris en Métal**

**Opbouwbeschrijving
Metalen Bergingen**

**Montageanweisungen
Metallgerätekäuser**

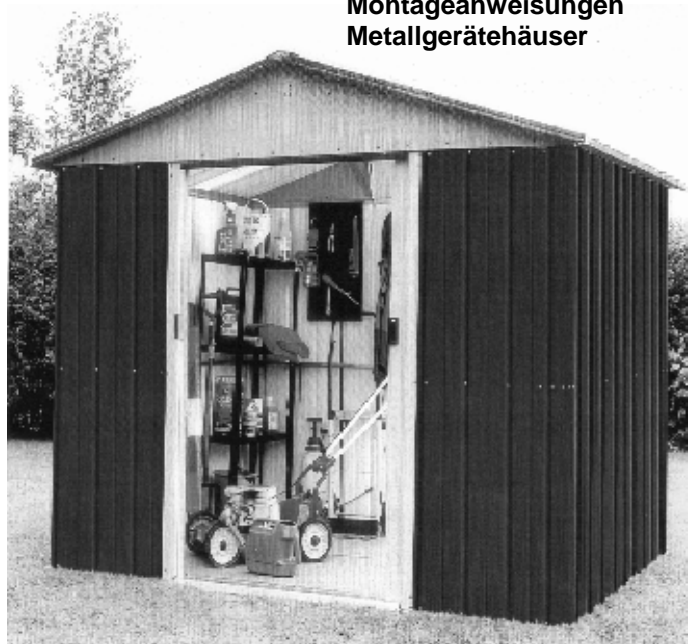

GREEN VERT GRÜN	
MODEL 66 GEYZ	
MODEL 67 GEYZ	
SILVER	
MODEL 66 ZGEY	
MODEL 67 ZGEY	

PARTS LIST	ONDERDELENLIJST	PART NO.	MODEL & QTY		LENGTH	
			66	67	MM	
PART DESCRIPTION	BESCHRIJVING VAN DE ONDERDELEN					
600 mm Wall Panel	600mm Wandpaneel	101EA	6	8	1600	
200 mm Wall Panel	200mm Wandpaneel	102EA	6	2	1600	
Corner Panel	Hoekpaneel	103EA	4	4	1600	
Front Panel	Voorpaneel	104.24EA	2	2	1600	
Inter-Roof Panel	Dak-Tussenplaat	201.20	2	2	1010	
Narrow Inter-Roof Panel	Smalle Dak-Tussenplaat	202.20	2	4	1010	
Left Hand Front/Right Hand	Dakplaat Linksvoor/Rechtsachter	203.19	2	2	1010	
Right Hand Front/Left Hand	Dakplaat Rechtsvoor/Linksachter	204.19	2	2	1010	
Gable Left Hand Front/Right	Geveltop-Linksvoor/Rechtsachter	301	2	2	920	
Gable Right Hand Front/Left	Geveltop- Rechtsvoor/Linksachter	302	2	2	920	
Base Rail	Funderingsrail	401.2	3	1	1833	
Base Rail	Funderingsrail	401.22	---	2	2033	
Side Brace	Zijklamp	402.2	3	1	1765	
Side Brace	Zijklamp	402.22	---	2	1965	
Front Brace	Voorklamp	403.2EA	2	2	465	
Corner Gusset	Hoekinzetstuk	406	4	4	86	
Notched Corner Gusset	Hoekinzetstuk	406EA	4	4	86	
Corner Gusset Stiffner	Versterking Van Hoekinzetstuk	407	2	2	150	
Front Anchor Bracket	Verankering Steun	407EA	2	2	69	
Door Guide	Deurgeleider	408409.2EA	2	2	634	
Side Beam	Zijbalk	501.2	2	---	1834	
Side Beam	Zijbalk	501.22	---	2	2034	
Roof Beam	Dakbalk	502.2	2	---	1834	
Roof Beam	Dakbalk	502.22	---	2	2034	
Ridge Cover	Nokplaat	503.02	1	1	615	
Ridge Cover	Nokplaat	503.03	---	1	415	
Ridge Cover	Nokplaat	503.07	---	1	490	
Ridge Cover	Nokplaat	503.08	2	1	690	
Roof Angle	Regengoot	504.01	4	2	1015	
Roof Angle	Regengoot	504.02	---	2	1365	
Ridge Cover Cap	Nokplaat Eindstuk	507	2	2	160	
Left Hand End Cap	Eindkap Linker	5081	2	2	45	
Right Hand End Cap	Eindkap Rechte	5091	2	2	45	
Left Hand Door	Linkerdeur	601.19	1	1	1593	
Right Hand Door	Rechterdeur	602.19	1	1	1593	
Gable Brace	Geveltop-Klamp	603.2	2	2	1800	
Door Track	Deurrail	X1790	1	1	1790	
Outer Door Post	Deurstijl Buitenzijde	604.01	2	2	1598	
Inner Door Post	Deurstijl Binnenzijde	106.03	2	2	1598	
Door Brace	Deurklamp	620.2	6	6	420	
Door Spacer	Deurhoekstuk	607EA	2	2	26	
Door Slider	Deurrolletje En Steun	6071	4	4	45	
Door Saddle	Deurslede	608.2EA	1	1	820	
Door Handle	Deurhendel	609	2	2	100	
Door Pelmet	Deurlijst	61501	1	1	820	

LISTE DE PIECES	TEILE-LISTE	PART NO.	MODEL & Qty			LENGTH
			66	67	MM	
DESCRIPTION DE LA PIECE	TEILE-BEZEICHNUNG					
Panneau Mural 600mm	600mm Wandplatten	101EA	6	8	1600	
Panneau Mural 200mm	200mm Wandplatten	102EA	6	2	1600	
Panneau D'angle	Eckplatten	103.EA	4	4	1600	
Panneau Avant	Vorderplatten	104.24EA	2	2	1600	
Panneau Toit (Milieu)	Dach-Zwischenplatten	201.20	2	2	1010	
Panneau Toit (Milieu) Étroit	Schmale Dach-Zwischenplatten	202.20	2	4	1010	
Panneau Toit Avant Gauche/Arrière	Linke Vordere Bzw. Hintere Rechte	203.19	2	2	1010	
Panneau Toit Avant Droite/Arrière	Rechte Vordere Bzw. Hintere Linke	204.19	2	2	1010	
Pignon-Avant Gauche/Arrière Droite	Giebel-Vorne Links Bzw. Hinten Rechts	301	2	2	920	
Pignon-Avant Droite/Arrière Gauche	Giebel-Vorne Rechts Bzw. Hinten Links	302	2	2	920	
Rail Base	Grundleiste	401.2	3	1	1833	
Rail Base	Grundleiste	401.22	---	2	2033	
Contreventement Latéral	Seitenstütze	402.2	3	1	1765	
Contreventement Latéral	Seitenstütze	402.22	---	2	1965	
Contreventement Avant	Vorderstütze	403.2EA	2	2	465	
Gousset D'angle	Eckenwinkel	406	4	4	86	
Gousset D'angle entaillé	Eckenwinkel	406EA	4	4	86	
Renfort De Gousset D'angle	Eckenwinkelversteifung	407	2	2	150	
Bride d'angle devant	Eckenwinkelversteifungen	407EA	2	2	69	
Guide De Porte	Türführung	408409.2EA	2	2	634	
Poutre Latérale	Seitenträger	501.2	2	---	1834	
Poutre Latérale	Seitenträger	501.22	---	2	2034	
Poutre Toit	Dachträger	502.2	2	---	1834	
Poutre Toit	Dachträger	502.22	---	2	2034	
Faîtière	Firstverkleidung	503.02	1	1	615	
Faîtière	Firstverkleidung	503.03	---	1	415	
Faîtière	Firstverkleidung	503.07	---	1	490	
Faîtière	Firstverkleidung	503.08	2	1	690	
Gouttière d'angle	Dachtraufverkleidung	504.01	4	2	1015	
Gouttière d'angle	Dachtraufverkleidung	504.02	---	2	1365	
Chape Faîtière	Firstverkleidungskappe	507	2	2	160	
Embout D'Extrémité De Gouttière	Linke Dachrinnen-Endkappen	5081	2	2	45	
Embout D'Extrémité De Gouttière	Rechte Dachrinnen-Endkappen	5091	2	2	45	
Porte Gauche	Linke Tür	601.19	1	1	1593	
Porte Droite	Rechte tür	602.19	1	1	1593	
Glissière De Pignon	Giebel-Vorne balken	603.2	2	2	1800	
Glissière De Porte	Türschienen	X1790	1	1	1790	
Montant De Porte Extérieur	TurauBenpfosten	604.01	2	2	1598	
Montant De Porte Intérieur	Türinnenpfosten	106.03	2	2	1598	
Porte Renforcee	Türstütze	620.2	6	6	420	
Coulisseau Bais	Tür-Distanzschiebe	607EA	2	2	26	
Coulisseau haut	Türschieber	6071	4	4	45	
Bride De Porte	Türschwelle	608.2EA	1	1	820	
Poignée De Porte	Türgriff	609	2	2	100	
Porte Renforcee	Türrandabdeckung	615.01	1	1	820	

WALL PANEL PANNEAU MURAL WANDPLATTEN WANDPANEEL

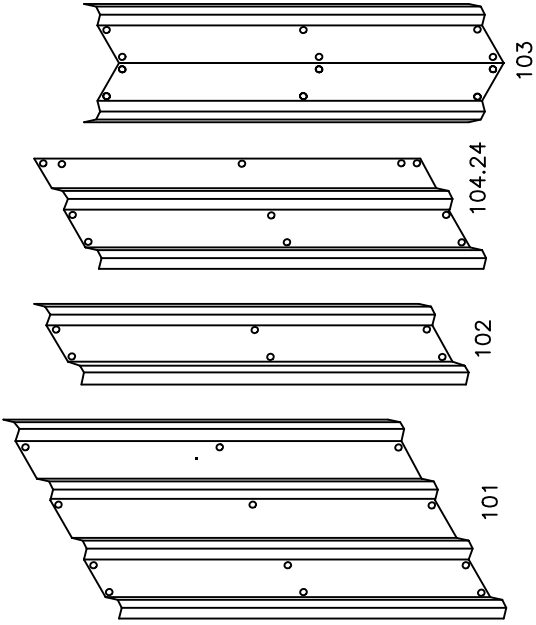

ROOF PANEL PANNEAU TOIT DACHPLATTE DAKPLAAT

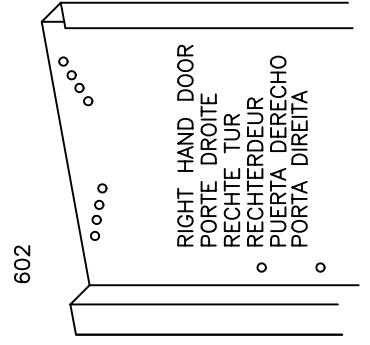
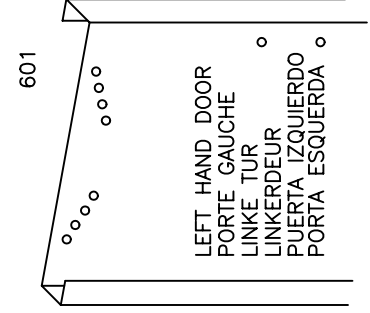
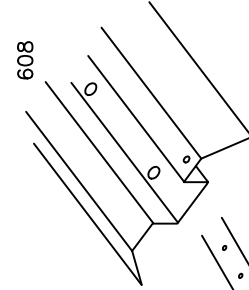
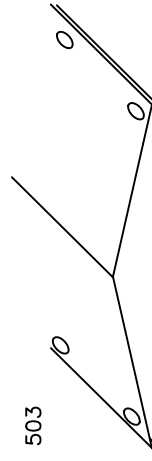
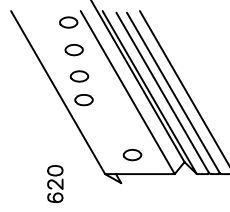
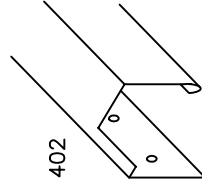
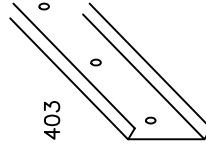
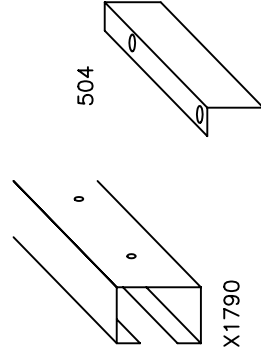
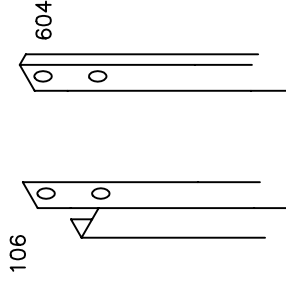
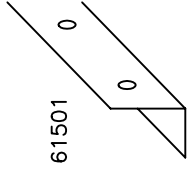
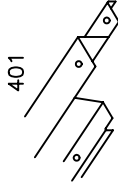
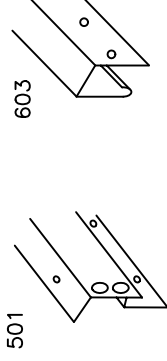
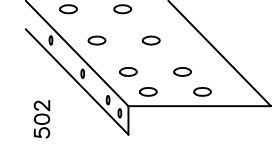
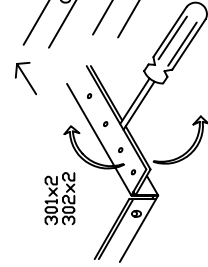
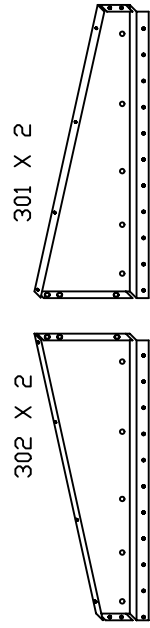
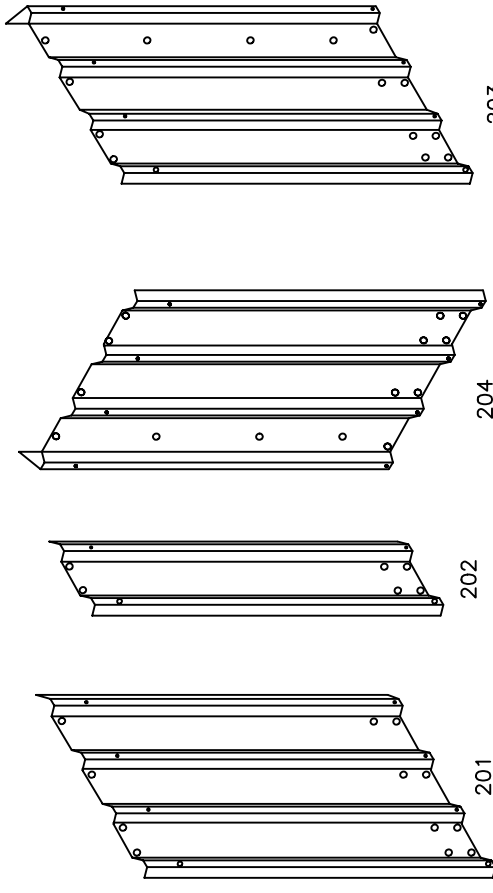

RIGHT HAND DOOR
PORTE DROITE
RECHTE TUR
RECHTERDEUR
PUERTA DERECHO
PORTA DIRETTA

LEFT HAND DOOR
PORTE GAUCHE
LINKE TUR
LINKERDEUR
PUERTA IZQUIERDO
PORTA ESQUERDA

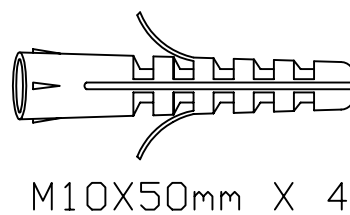
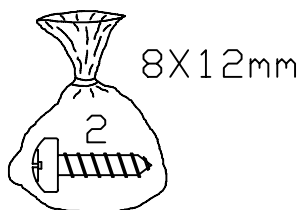
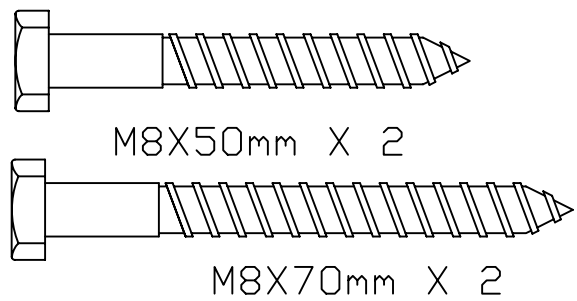
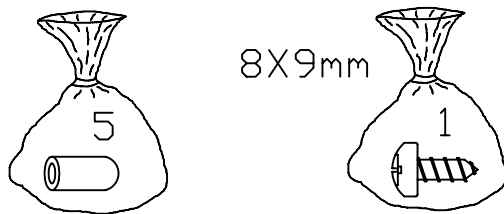
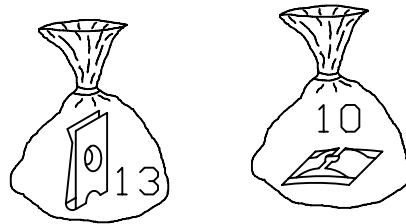
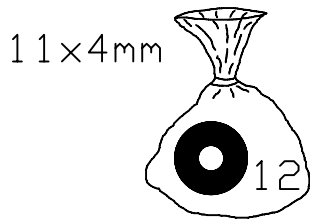
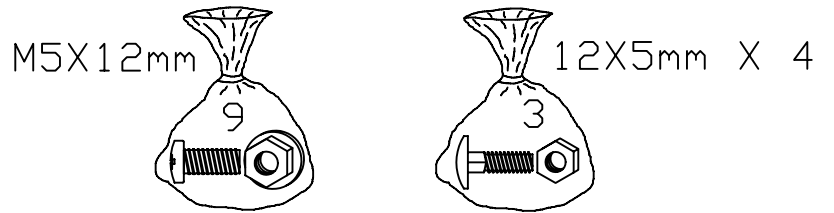
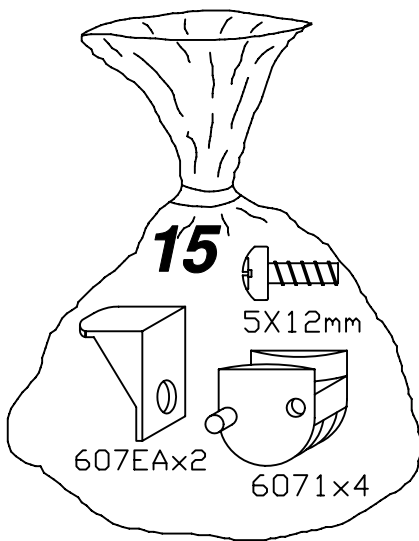
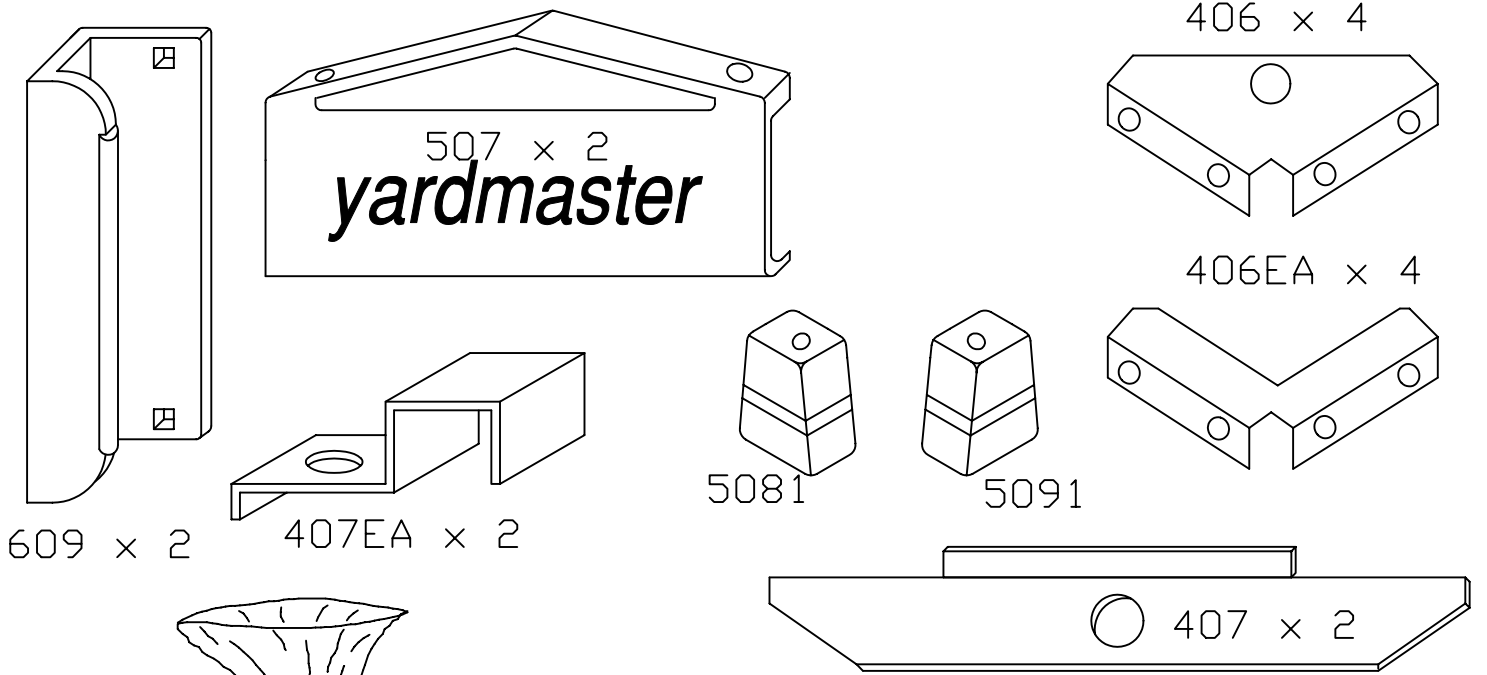

M8X19mm X 4

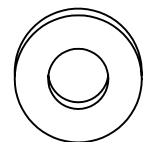

ASSEMBLY INSTRUCTIONS (ENGLISH) MODEL 63-65 GEY/ZGEY.

Before starting, read through the assembly instructions carefully. Check thoroughly all the parts you have received against the parts list (page 1) and the diagram (page 3,4). Ensure that no parts are damaged.

THINGS TO REMEMBER !

- 1. WEATHER WARNING ! DO NOT ERECT YOUR BUILDING ON A WINDY DAY. ANY BUILDING LEFT PARTIALLY CONSTRUCTED MAY BE SERIOUSLY DAMAGED (FIG.1).**
- 2. ALWAYS ASSEMBLE THE ROOF FIRST STEPS 2 & 3, ESPECIALLY IF YOU DO NOT INTEND TO COMPLETE CONSTRUCTION ON THE SAME DAY.**
- 3. ALL ASSEMBLY OPERATIONS MUST TAKE PLACE ON A COMPLETELY LEVEL SURFACE (FIG. 1)**
- 4. UNLESS OTHERWISE STATED SCREWS AND FIBRE WASHERS (BAGS 1 AND 12) MUST BE USED IN ALL ASSEMBLY OPERATIONS.**
- 5. IT IS RECOMMENDED THAT YOU WEAR THE GLOVES PROVIDED WHEN ASSEMBLING THIS PRODUCT.**
- 6. THE SHED SHOULD BE SECURELY ANCHORED TO A FIRM LEVEL BASE EG CONCRETE, PAVING SLABS WOOD ETC FOR CONCRETE BASE SEE BELOW.**

SITE PREPARATION CONCRETE.

1. Concrete should be laid a minimum of 75mm thick and at least 100mm greater than the overall size of the metal base frame at approx. 25mm above ground level. A sheet of heavy duty polythene placed under the base area will help prevent dampness rising from the ground into the shed. For concrete base measurements see fig. 2.

NOTICE DE MONTAGE 63-65 GEY/GEY.

Avant de commencer à lire attentivement la notice de montage, vérifiez précisément si vous avez bien reçu toutes les pièces énoncées sur la liste page 2, ainsi que sur le schéma page 3&4. Assurez vous qu'aucune pièce n'a été endommagée.

N'OUBLIEZ PAS !

- 1. TEMPÊTE DE VENT: NE JAMAIS MONTER VOTRE ABRI PAR GRAND VENT. NE PAS LAISSER UN ABRI**

PARTIELLEMENT MONTÉ, LES PIÈCES POUVANT ÊTRE ENDOMMAGÉES (FIG. 1).

- 2. ASSEMBLER EN PRIORITÉ LE TOIT (ÉTAPE 2 ET 3) SURTOUT SI VOUS PENSEZ NE PAS FINIR LE MONTAGE DANS LA JOURNÉE.**
- 3. TOUTES LES OPÉRATIONS DE MONTAGE DOIVENT ÊTRE RÉALISÉES SUR UNE SURFACE PLANE (fig 1).**
- 4. UTILISER SUR TOUTES LES VIS À MÉTAUX D'ASSEMBLAGE (SAC NO 1) LES RONDELLES D'ÉTANCHÉITÉ EN FIBRE (SAC NO 12).**
- 5. IL EST RECOMMANDÉ QUE VOUS PORTIEZ LES GANTS PRÉVUS À CET EFFET LORS DU MONTAGE DE VOTRE ABRI.**
- 6. L'ABRI DOIT ÊTRE FIXE AU SOL SUR UNE SURFACE PLANE, PAR EXEMPLE, BÉTON, DALLES EN BÉTON, BOIS ETC. POUR UNE SURFACE DE BÉTON, VOIR CI-DESSUS.**

PRÉPARATION DE LA DALLE:

1. Le béton doit être coulé sur une épaisseur de 75mm, et dépasser de 100mm la hauteur du profilé de base soit 25mm au dessus du niveau du sol. L'utilisation d'une toile de polythène épaisse et résistante, placée sous la base aidera à empêcher l'humidité de monter du sol dans l'abri. Pour les dimensions de la dalle en béton, vous reporter à la fig. 2.

MODELLE 63 - 65 GEY/ZGEY MONTAGEANLEITUNG

VOR BEGINN:

1. Machen Sie sich mit den Montageanweisungen vertraut.
2. Überzeugen Sie sich an Hand der Teilliste (Seite 2) und der Schaubilder (seite 3 &4), ob alles vollzählig ist und die Teile nicht beschädigt sind.

WICHTIG

- 1. STELLEN SIE DAS HAUS NICHT AN EINEM STÜRMISCHEN TAG AUF. JEDES HAUS WÜRDE UNTER SOLCHEN WETTER-BEDINGUNGEN BESCHÄDIGT WORDEN.**
- 2. DER GARTENSCHUPPEN MUß AUF EINER VOLLSTÄNDIG EBENEN FLÄCHE ERRICHTET WERDEN.**
- 3. SOFERN NICHT ANDERS ANGEZEIGT BENÜTZEN SIE DIE SCHRAUBEN UND WASSERDICHTEN FASERSCHLEIBEN (BEUTEL 1 & 12) BEI ALLEN MONTAGEGÄNGEN.**
- 4. TRAGEN SIE DIE BELIEFERTEN HANDSCHUHE BEI DER MONTAGE.**
- 5. ES IST EMPFEHLENSWERT ZUERST**

**DAS DACH ZU MONTIEREN
BESONDERS**

**WENN SIE DEN AUFBAU NICHT AN
SELBEN TAG BEENDEN WOLLEN.**

- 6. DAS HAUS MUß AUF EINER FESTEN
EBENEN FLÄCHE VERANKERT**

**WERDEN, Z.B. AUF BETON,
BETONPLATTEN, HOLZ. BEI
BETONFLÄCHEN SEHEN SIE UNTEN.**

VORBEREITUNG DES BETONFUNDAMENTS:

Die Betonplattform soll mindestens 70-80mm stark und mindestens 100mm länger und breiter als der metall-grundrahmen sein. die plattform sollte außerdem mindestens 25mm über dem boden sein.
Ein laken aus hochleistungskunststoff unter dem fundament wird dazu helfen, feuchtigkeit vorzubeugen, die von der erde in den schuppen hineindringt.

BOUWHANDLEIDING MODELLEN 63 - 65 GEY/GEY

Voordat U met de bouw begint, maakt U zich dan eerst goed vertrouwd met de bouwaanwijzingen.
Kruis alle ontvangen onderdelen op de onderdelenlijst (pagina 1) en diagram (pagina 3&4) aan. Controleer of de onderdelen niet zijn beschadigd.

BELANGRIJK !

- 1 MONTEER UW SCHUUR NIET OP EEN WINDERIGE DAG. DE KANS DAT ER TÏDENS HET MONTEREN BESCHADIGINGEN ONTSTAAN IS DAN ZEER GROOT AANWEZIG (Afb 1).**
- 2 HET IS AAN TE RADEN , OM EERST HET DAK TE MONTEREN, STAP 2 & 3 VOORAL ALS U NIET VAN PLAN BENT OM HET COMPLETE SCHUURTJE IN EIN DAG TE MONTEREN.**
- 3 DE BOUW DIENT UITGEVOERD TE WORDEN OP EEN GEHEEL VLAKKIE ONDERGROND (Afb 1)**
- 4 TENZY ANDERS AANGEGEVEN MOETEN BIJ HET MONTEREN DE SCHROEVEN EN VEZELRINGEN UIT (Zak 1 en 12) WORDEN GEBR UIKT.**
- 5 HET IS AAN TE RADEN DE MEEGELEVERDE HANDSCHOENEN BIJ HET MONTEREN TE DRAGEN**

VOORBEREIDING VAN DE BOUWPLAATS VAN BETON

1 Het beton dient minimaal 75mm dik te worden gelegd. Ongeveer 25mm boven grondniveau dient het beton minstens 100mm breder te zijn dan de totale maal van het metalen funderingsraam.
Afb. 2.

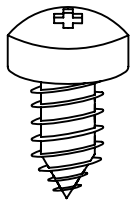

WASHERS TO BE USED ON ALL SCREWS
 VEZELRINGEN VOOR GEBRUIK ONDER ALLE SCHROEVEN
 RONDELLES POUR TOUTES LES VIS
 FASER SCHEIBEN FÜR VERWENDUNG MIT ALLEN SCHRAUBEN
 ARANDELAS QUE DEBEN USARSE CON TODOS LOS TORNILLOS
 ANILHAS PARA SEREM UTILIZADAS EM TODOSMOS PARAFUSOS

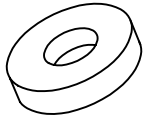

FIG. 1

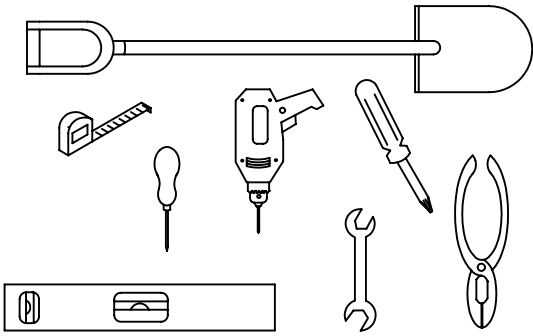
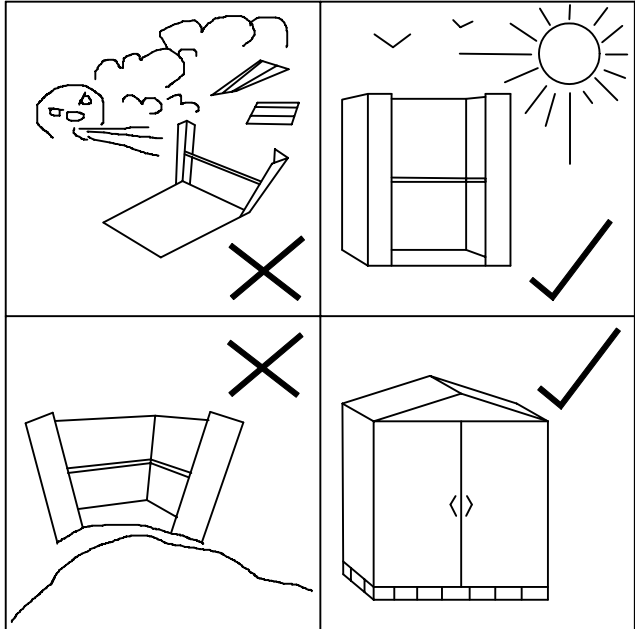
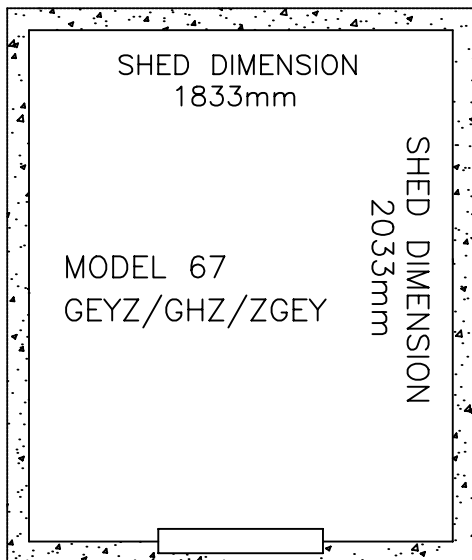

FIG. 2

BASE DIMENSION
2000mm



FRONT DEVANT FREITE
 VOORKANT VORDERSEITE

BASE DIMENSION
2000mm

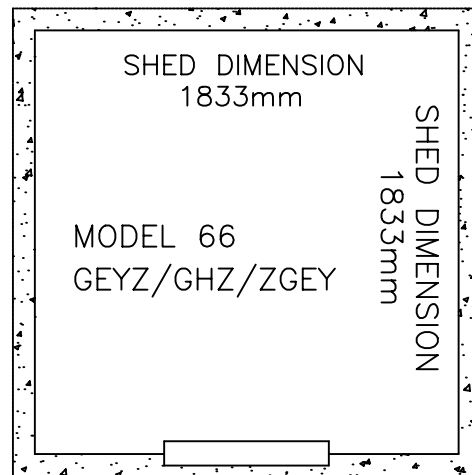

FRONT DEVANT FREITE
 VOORKANT VORDERSEITE

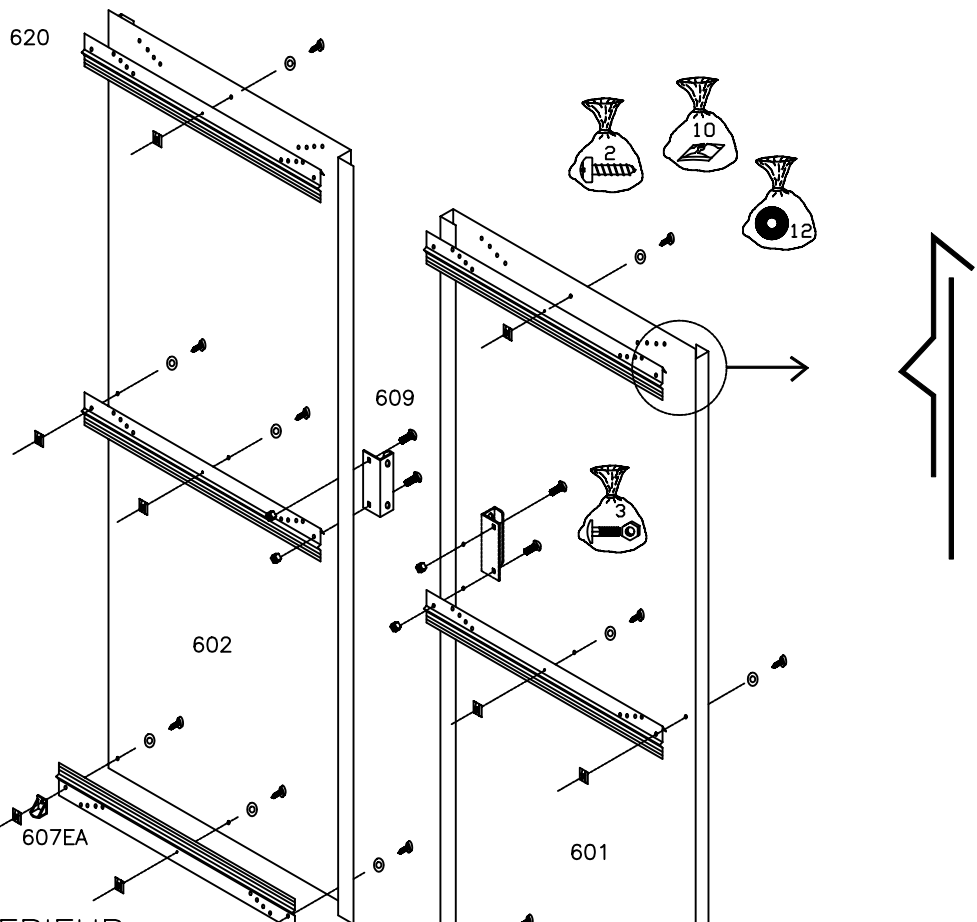

A L'INTERIEUR
INNENSEITE

View shows Door Brace
being fitted to
inside of doors.

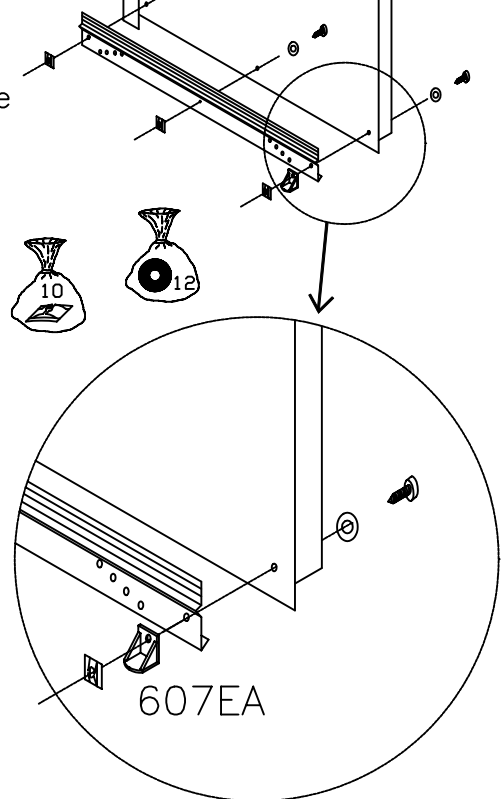

INSIDE
A L'INTERIEUR
INNENSEITE

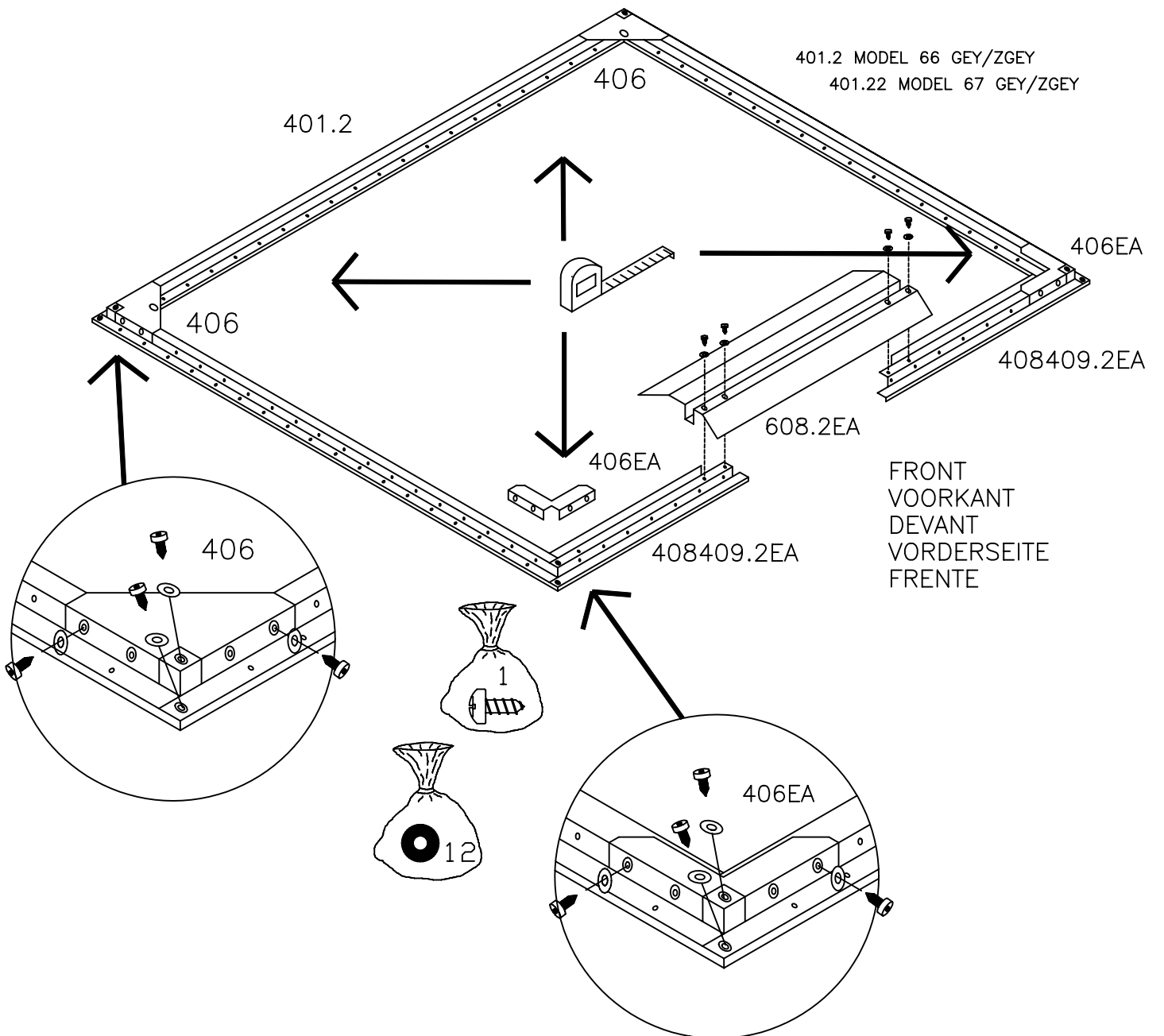
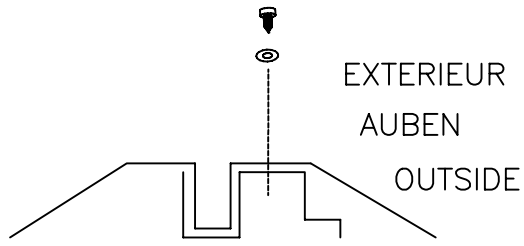

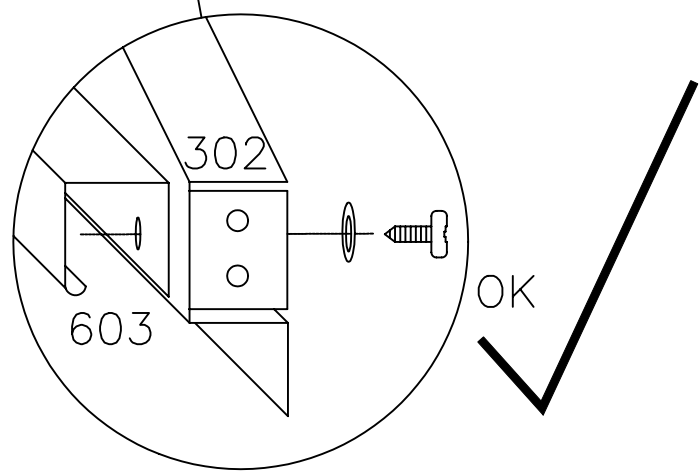
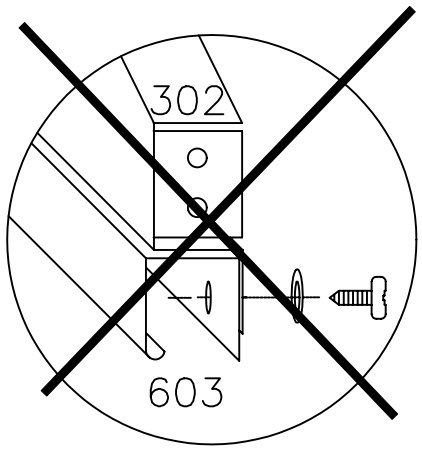
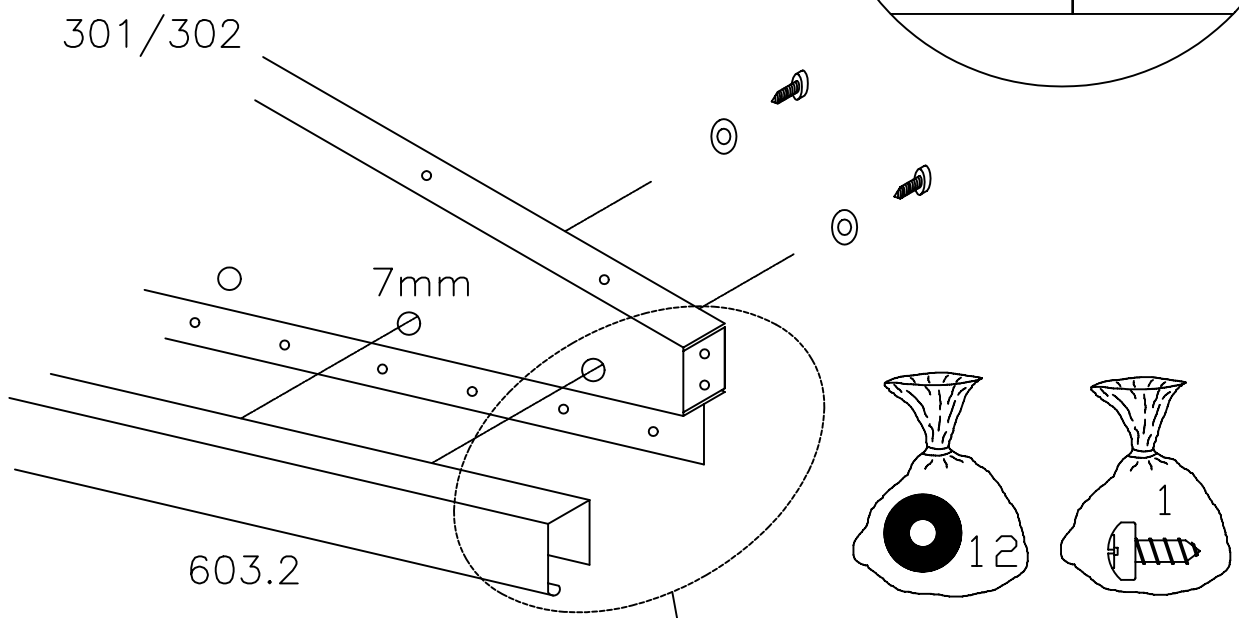
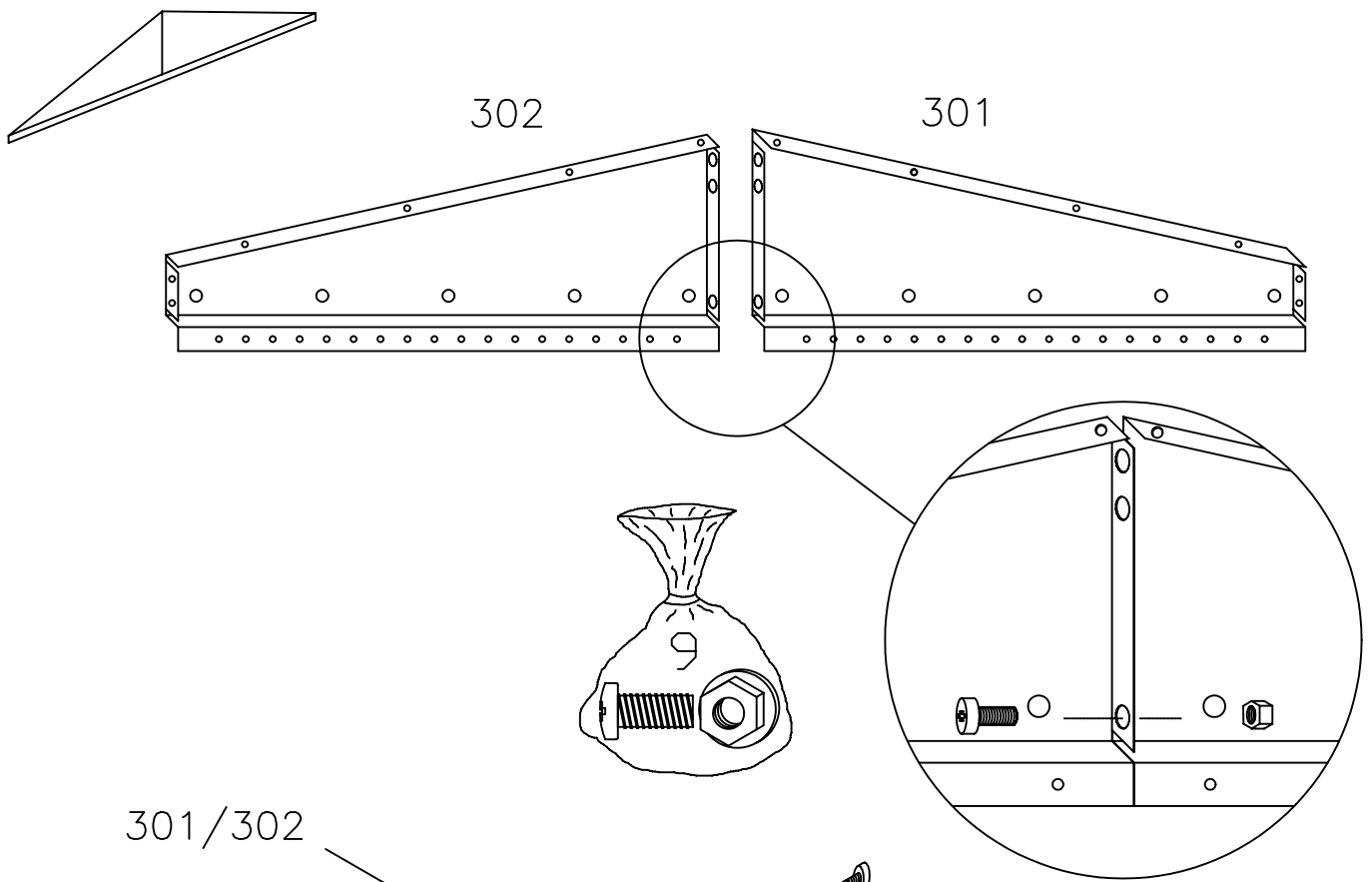

Fix Through 7mm Holes in Gables.

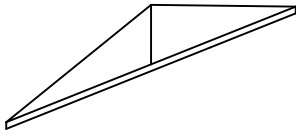

302

301

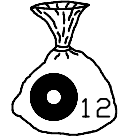
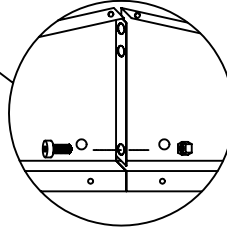
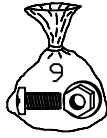
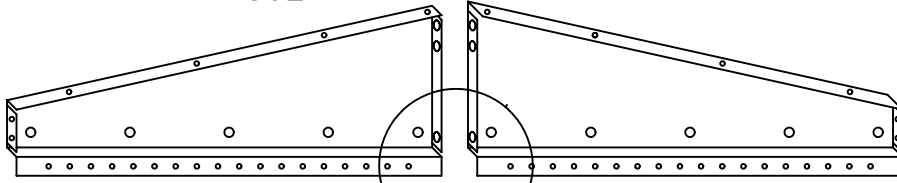

FRONT GABLES
 GEVELTOP-VOORKANT
 FACHADA FRONTAL
 PIGNON-AVANT
 GIEBEL-VORNE
 EMPENA FRONTAL

Secure With Four Screws
 Until Roof Is Fitted To Walls

FIXER EN UTILISANT 4 ECROUS
 AFIN QUE LE TOIT EST
 ATTACHE AUX MURS

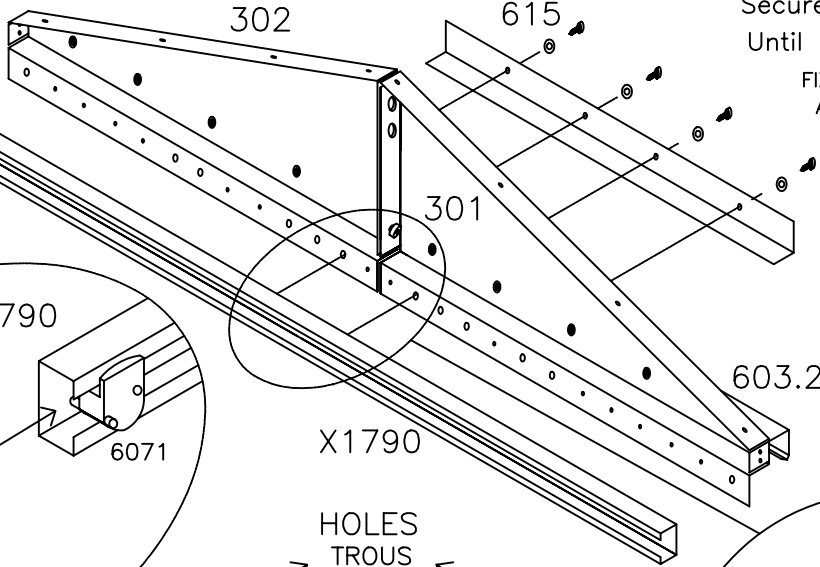

X1790

302

615

301

603.2

X1790

X1790

6071

6071

6071

6071

HOLES
TROUS

PINS
EPINGLE

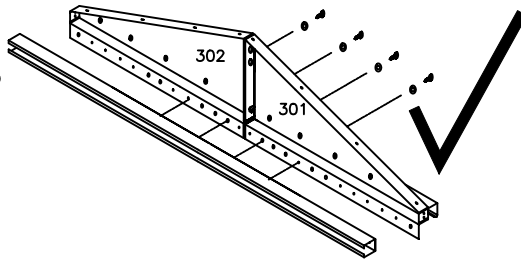
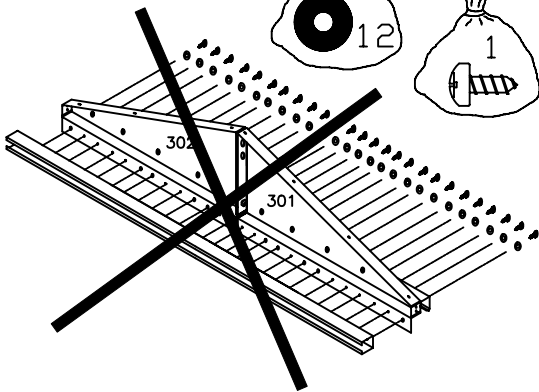
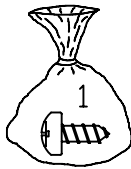
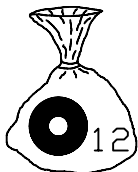
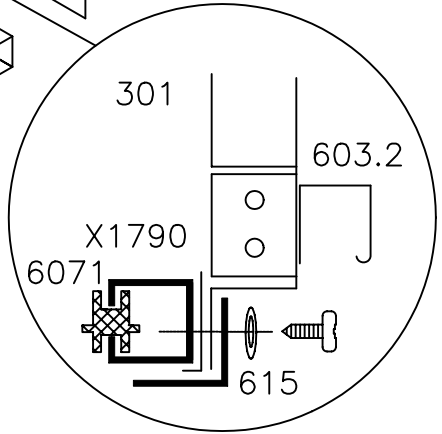
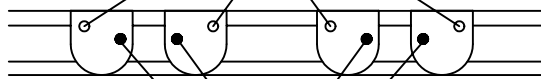

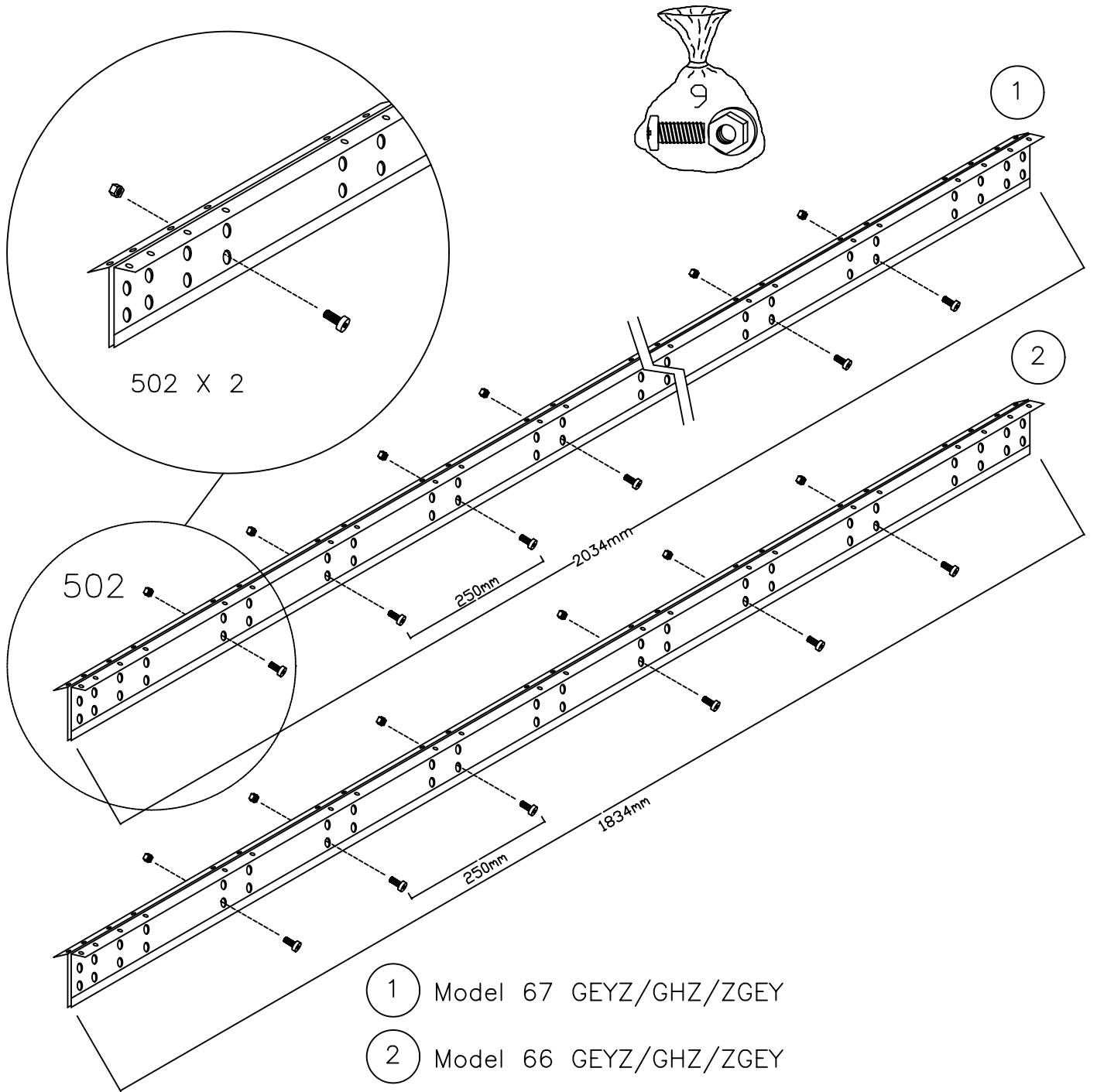

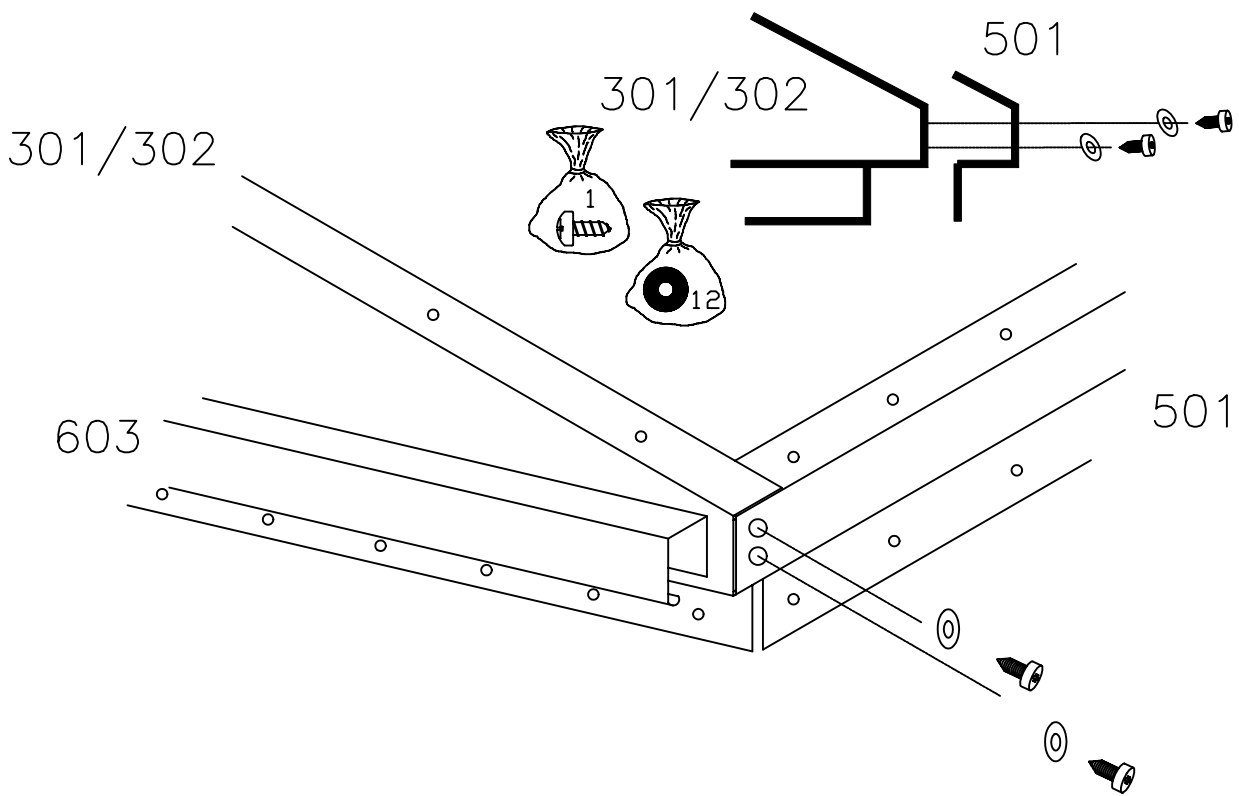
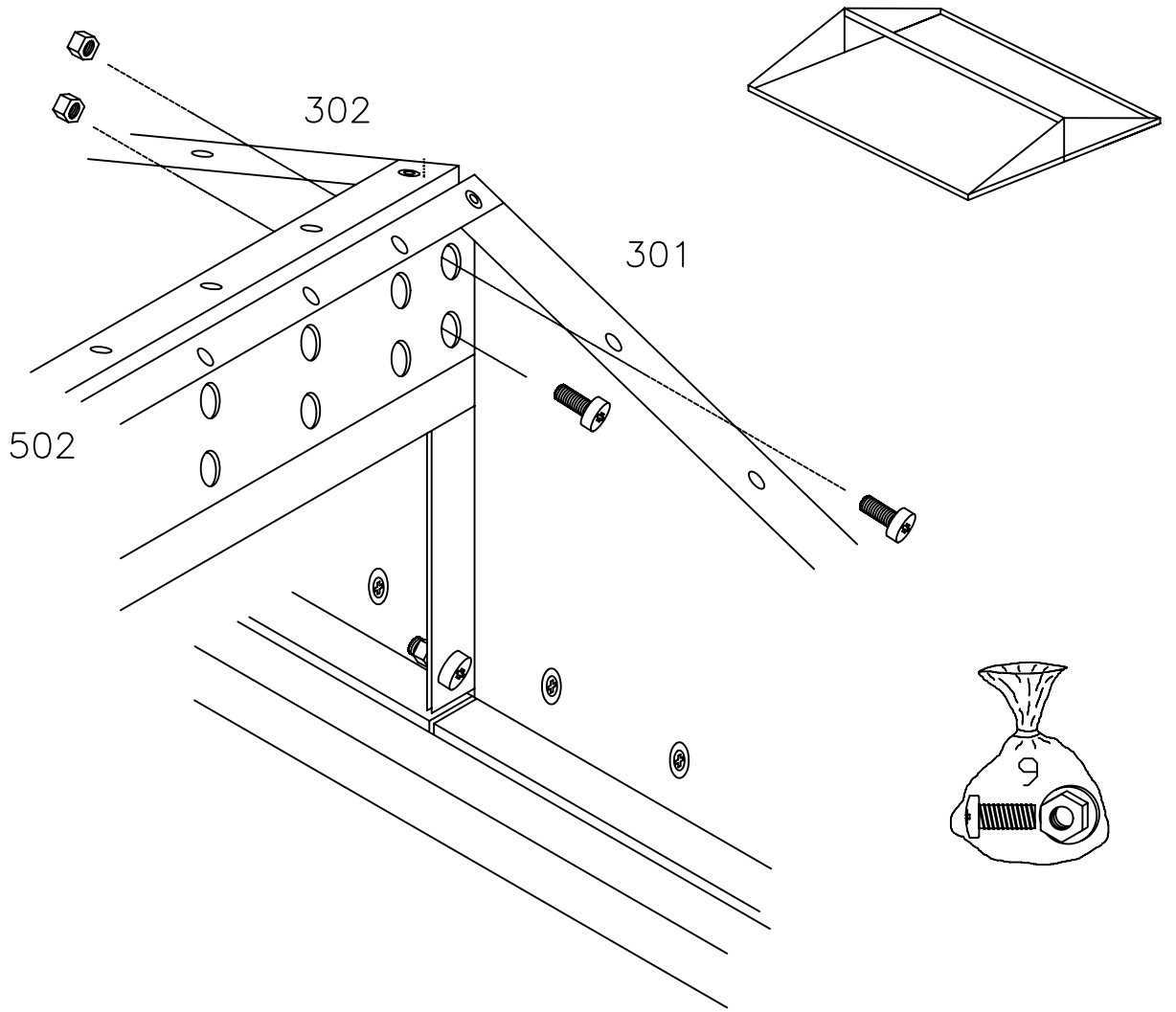

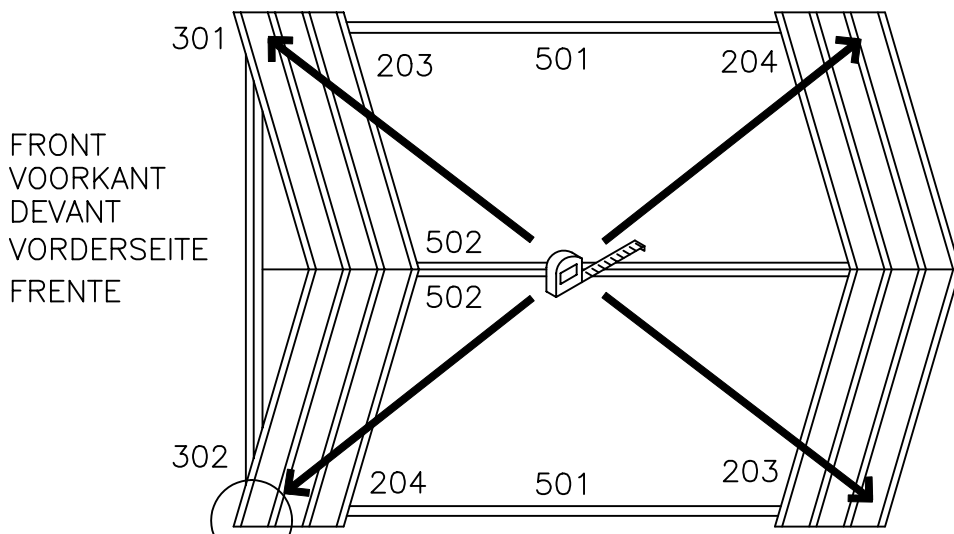
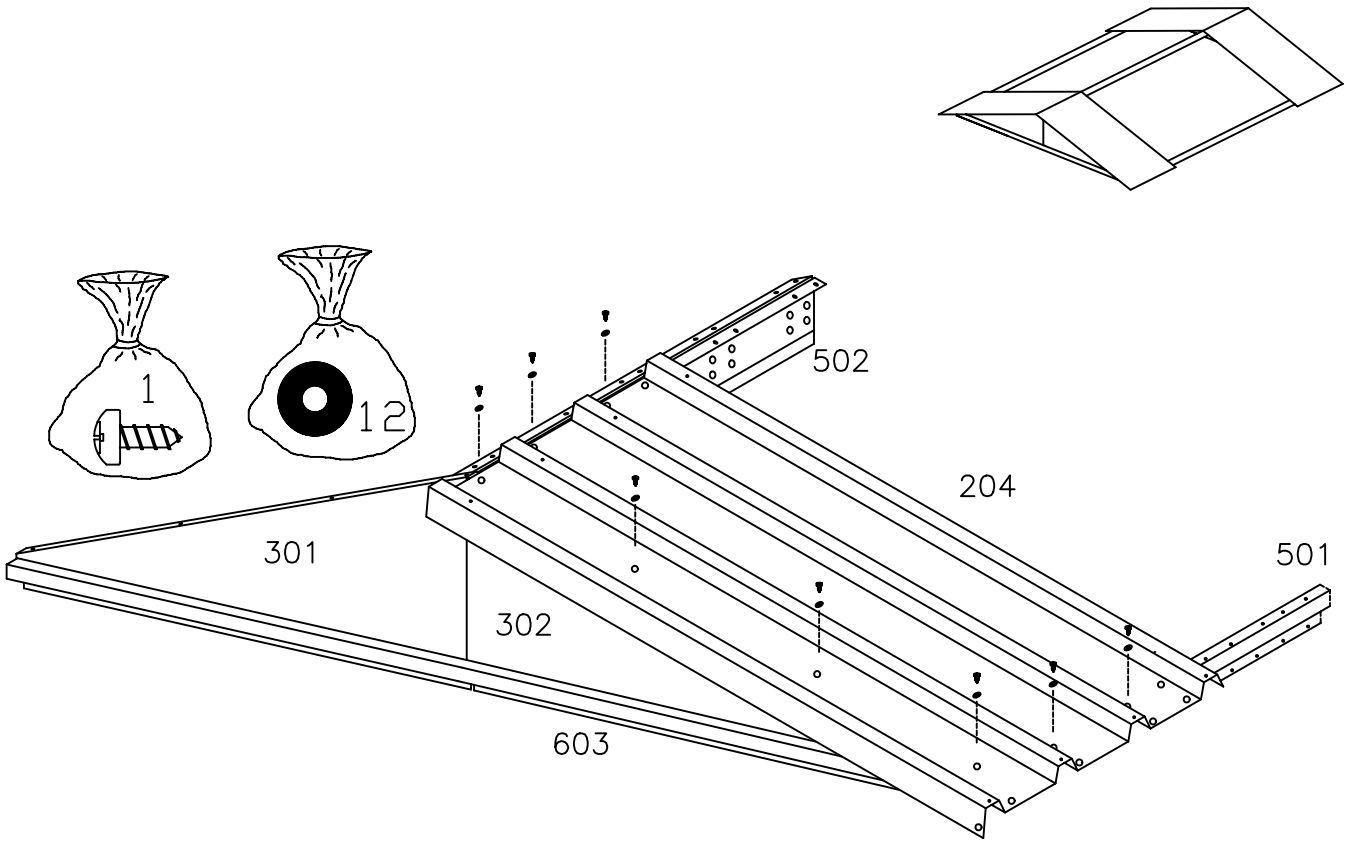

FRONT
 VOORKANT
 DEVANT
 VORDERSEITE
 FRENTE

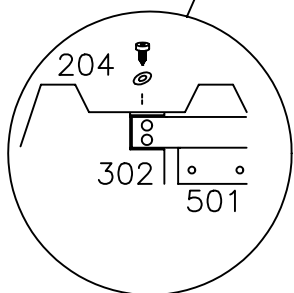

DO NOT TIGHTEN SCREWS
 UNTIL 203 AND 204 CORNER
 ROOF PANELS ARE LINED UP
 AND ROOF FRAME IS "SQUARE"

ENSURE ROOF FRAME
 IS "SQUARE" BEFORE
 SECURING PANELS
 DACHRAHMEN RECHTWINKLIG
 VOR DACHPLATTEN
 FESTZUMACHEN
 EQUARREZ LE METIER
 AVANT DE FIXER
 LES PANNEAUX

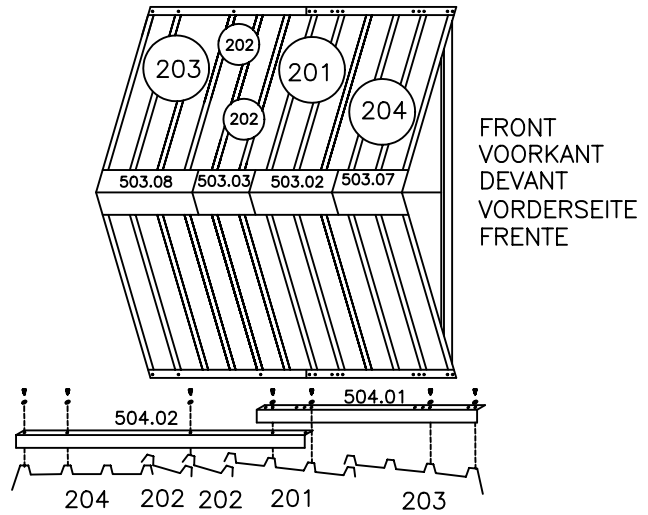
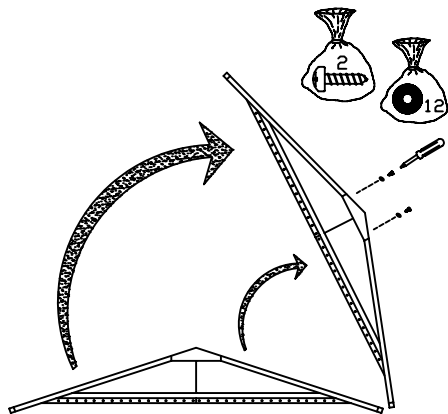
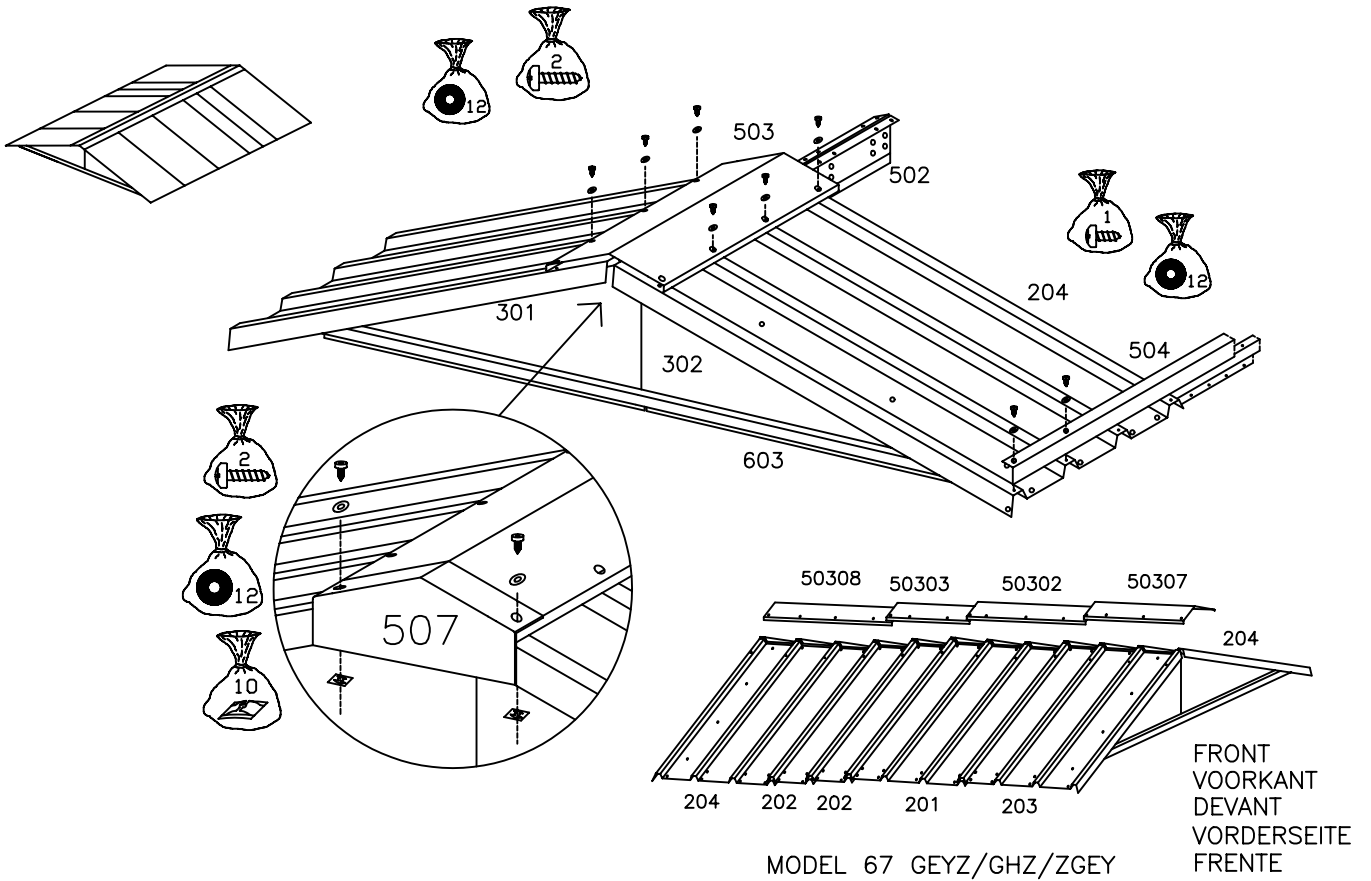

MODEL 66 GEYZ/GHZ/ZGEY

FRONT
VOORKANT
DEVANT
VORDERSEITE
FRENTE

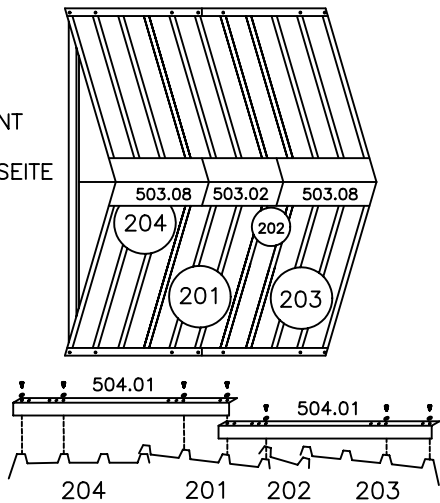

MODEL 67 GEYZ/GHZ/ZGEY

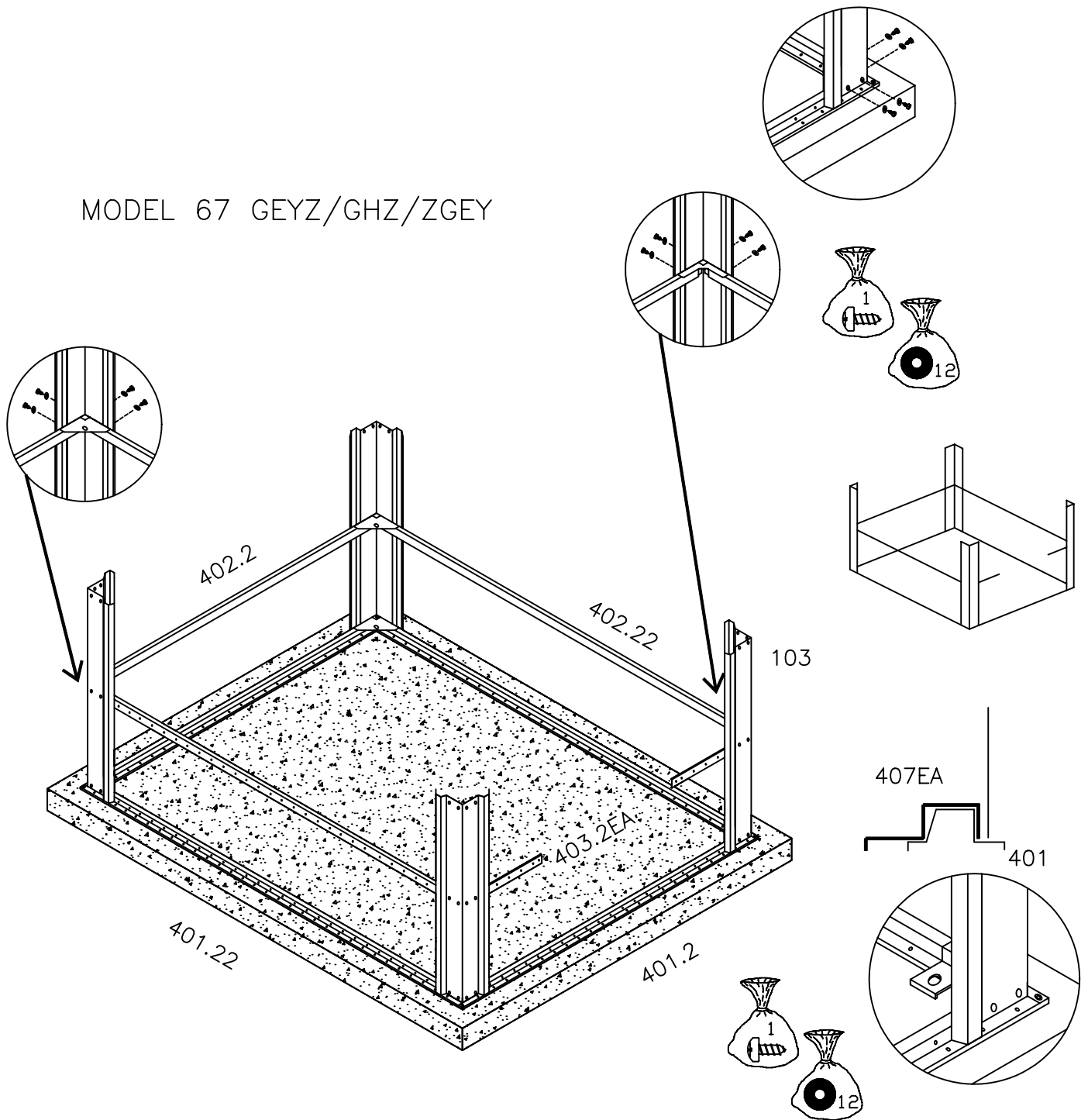

402



NOTE ! 403.2EA FRONT BRACE IS A DIFFERENT PROFILE THAN 402

403.2EA



MODEL 66 GEYZ/GHZ/ZGEY

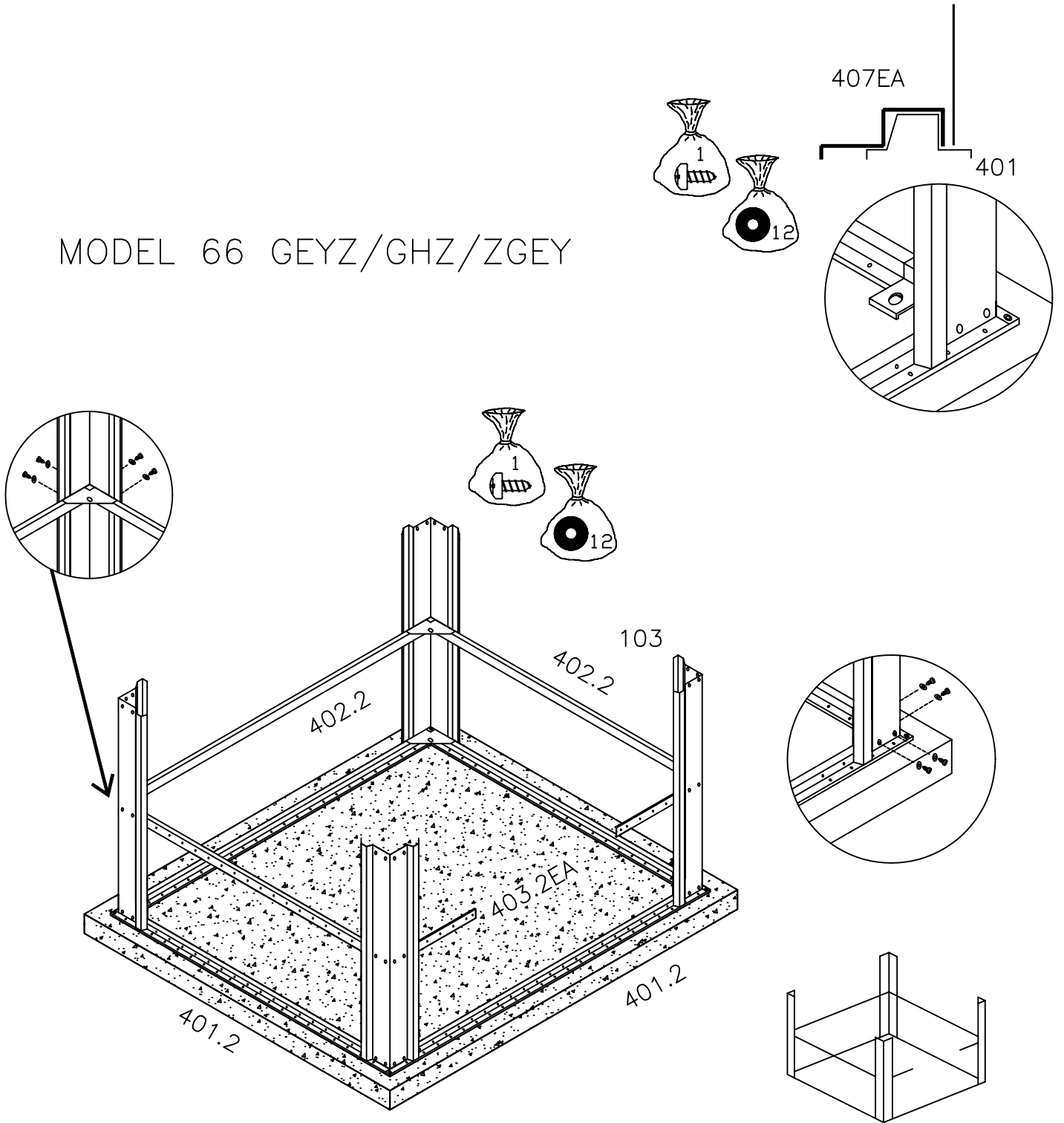

402



NOTE ! 403.2EA FRONT BRACE IS A DIFFERENT PROFILE THAN 402

403.2EA



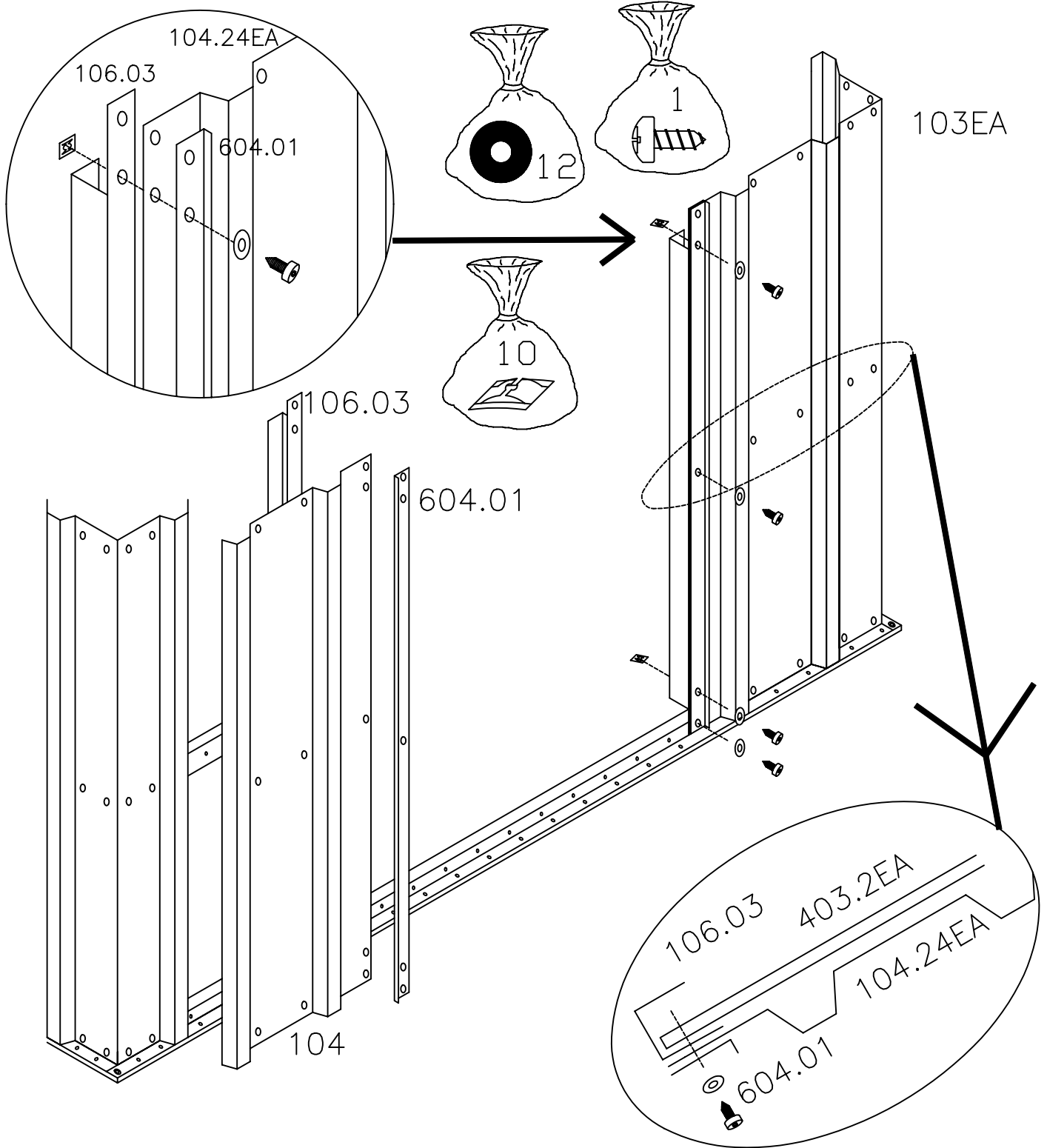

WALL PANEL ASSEMBLY
 MONTEREN VAN WANDPANEEL
 MONTAGE DE LA PANNEAU MURAL
 WANDPLATTEN MONTAGE
 PAINEL DA PAREDE
 PANELES DE LA PARED

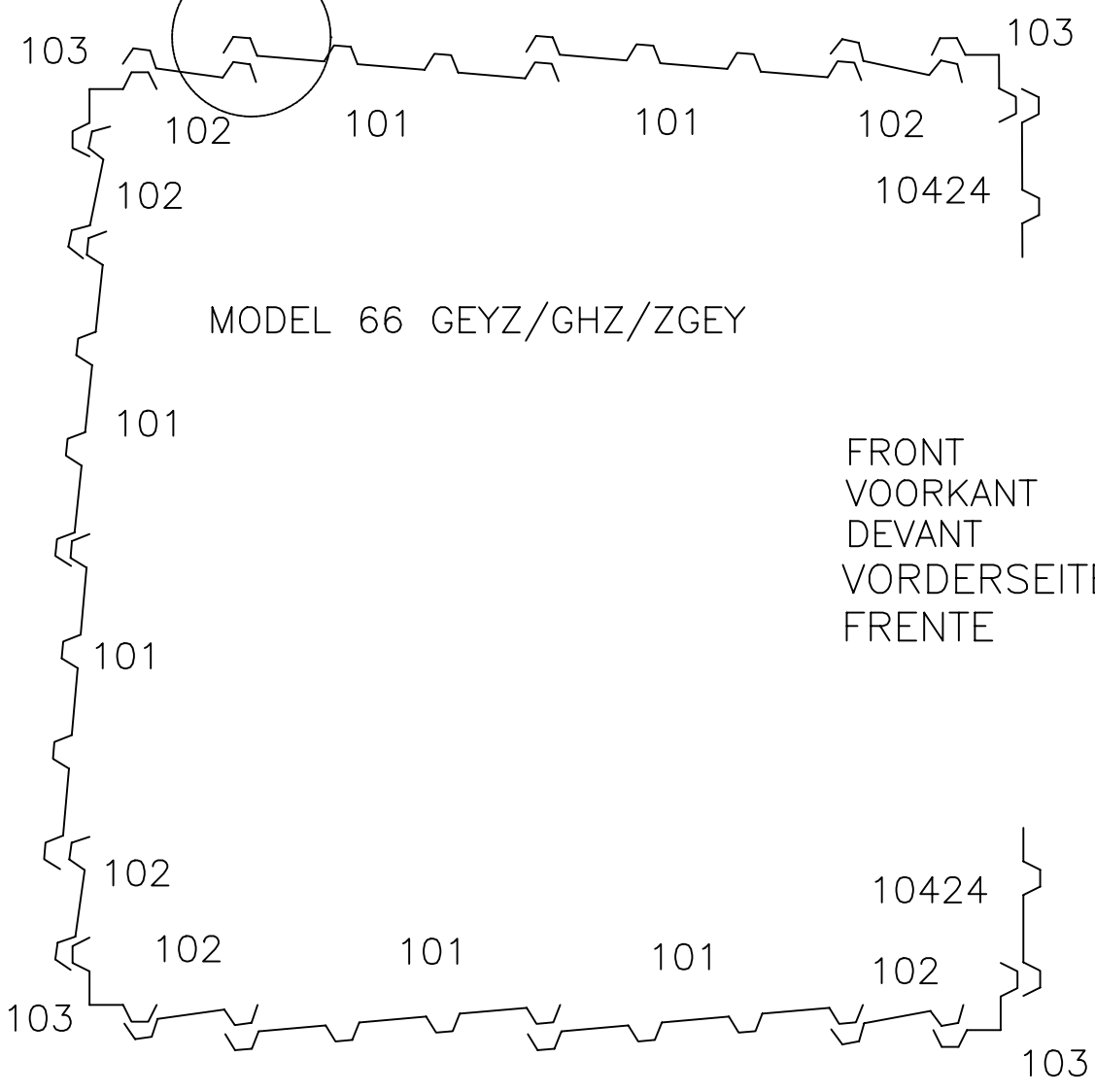
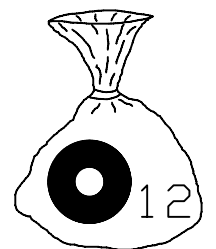
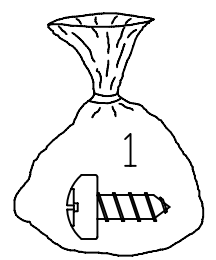
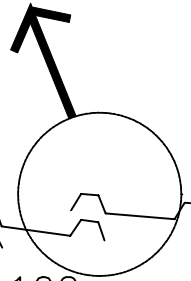
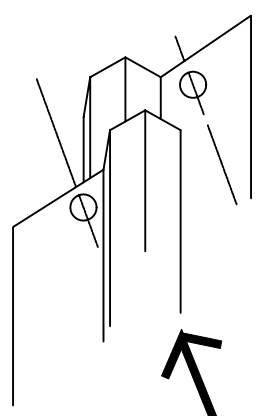

FRONT
 VOORKANT
 DEVANT
 VORDERSEITE
 FRENTE

WALL PANEL ASSEMBLY
 MONTEREN VAN WANDPANEEL
 MONTAGE DE LA PANNEAU MURAL
 WANDPLATTEN MONTAGE
 PAINEL DA PAREDE
 PANELES DE LA PARED

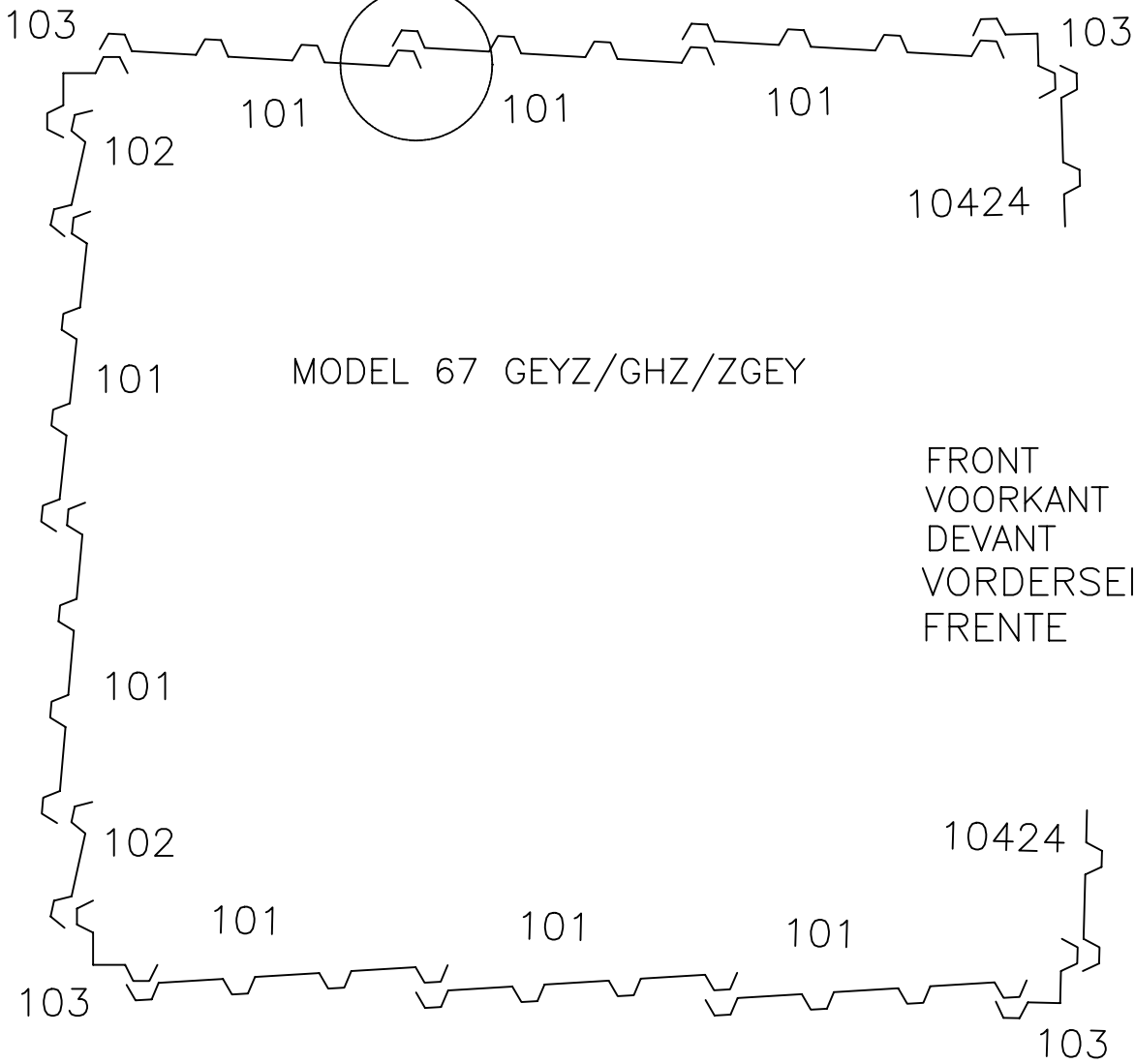
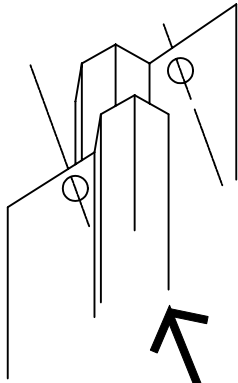

MODEL 67 GEYZ/GHZ/ZGEY

FRONT
 VOORKANT
 DEVANT
 VORDERSEITE
 FRENTE

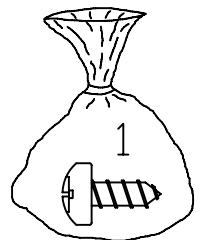
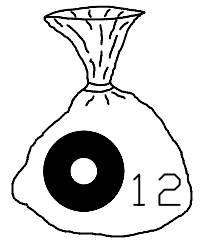

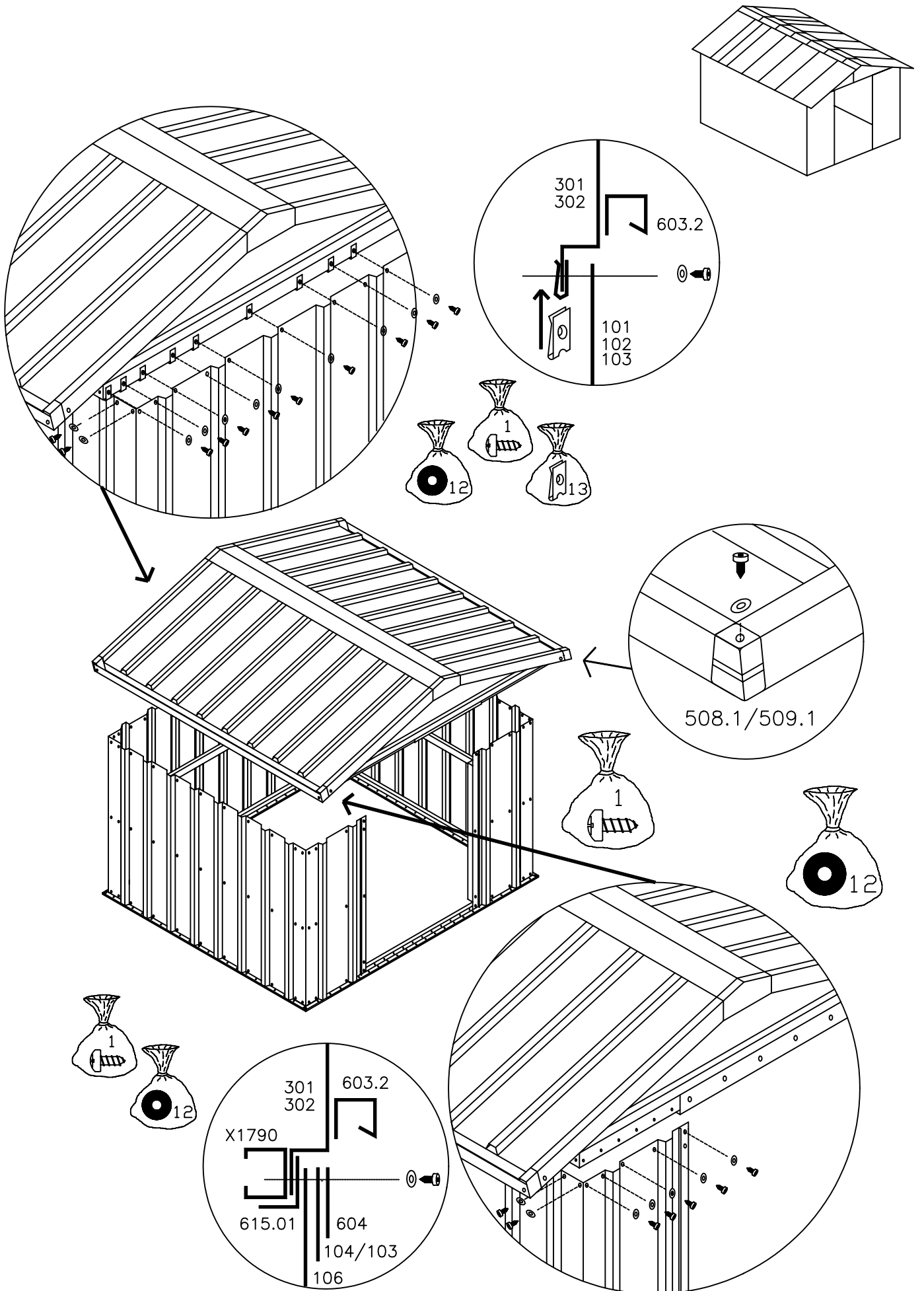

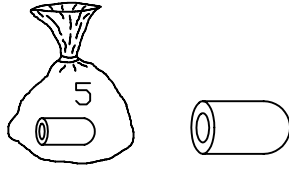

- BAG NO. 5 PLASTIC TIPS USED ON EXPOSED SCREW POINTS ON INSIDE WALLS
 SAC NO. 5 CAPUCHONS EN PLASTIQUE POUR POINTES DE VIS NUES SUR LES PAROIS INTERIEURES
 BEUTEL NO. 5 PLASTIK-AUFSTECKHUTCHEN FUR DIE SCHRAUBENSPIZEN AN DEN INNENWANDEN
 ZAK NO. 5 PLASTIC DOPJES VOOR SCHROEFUITEINDEN AAN DE BINNENWAND
 BOLSA NO. 5 TAPONES DE PLASTICO PARA UTILIZAR EN PUNTOS DONDE QUEDE EXPUESTO EL TORNILLO EN LAS PAREDES INTERIORES
 SACO NO. 5 PONTEIRAS PLASTICAS PARA PONTAS DE PARAFUSOS EXPOSTAS NAS PAREDES INTERIORES

