

Please Direct Enquires To:

Yardmaster International
Cahore Road
Draperstown
BT45 7AP.
Tel: 028 796 28449

**Demandes de
Renseignements à :**

TRIGANO JARDIN
Service Commercial
Usine du Boulay
41170 Cormenon
Mondoubleau
Tel: (02) 54 73 55 55

Bitte alle Anfragen an:

I.N.I.
Kaistraße 7-9
40221 Düsseldorf
Tel: 0211 30 21 28 15

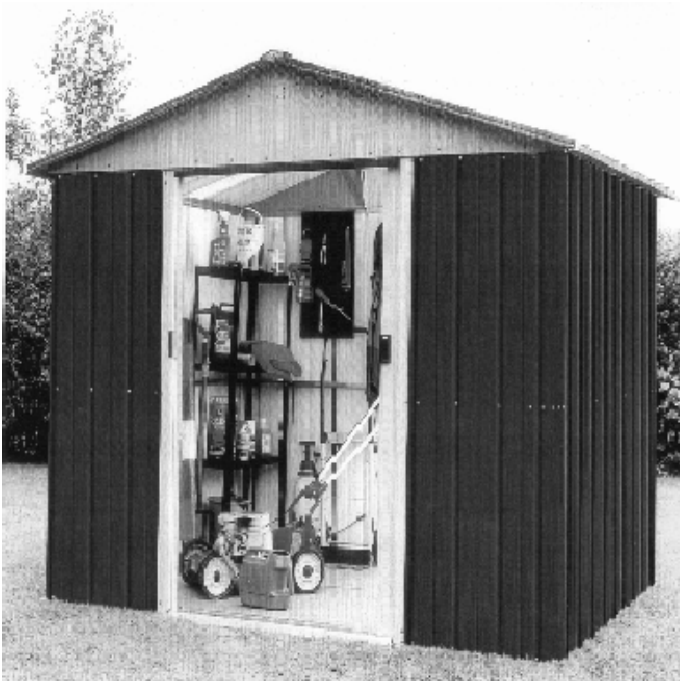

**Assembly
Instructions**

**Montageanweisungen
Metallgerätehäuser**

**Notice de montage
Abri de Jardin Métallique**

**Opbouwbeschrijving
Metalen Bergingen**

GREEN VERT GRÜN	
MODEL 107 GEYZ	
SILVER	
MODEL 107 ZGEY	

PARTS LIST	ONDERDELENLIJST	PART NO.	Mod	LENGTH	
PART DESCRIPTION	BESCHRIJVING VAN DE ONDERDELEN		107	MM	
600 mm Wall Panel	600mm Wandpaneel	101EA	12	1600	
Corner Panel	Hoekpaneel	103EA	4	1600	
200mm Wall Panel	200mm Wandpaneel	102EA	1	1600	
Door Post	Deurstijl	106.29	2	1600	
Inter-Roof Panel	Dak-Tussenplaat	201.3	2	1520	
Inter-Roof Panel 200mm	Dak-Tussenplaat 200mm	202.3	4	1520	
Left Hand Front/Right Hand Rear Roof Panel	Dakplaat Linksvoor/Rechtsachter	203.29	2	1520	
Right Hand Front/Left Hand Rear Roof Panel	Dakplaat Rechtsvoor/Linksachter	204.29	2	1520	
Gable Left Hand Front/Right Hand Rear	Geveltop- Linksvoor/Rechtsachter	301	2	920	
Gable Right Hand Front/Left Hand Rear	Geveltop- Rechtsvoor/Linksachter	302	2	920	
Centre Gables	Geveltoppen-Midden	305.3	2	995	
Base Rail	Funderingsrail	401.10	2	1033	
Base Rail	Funderingsrail	401.14	3	1233	
Base Rail	Funderingsrail	401.2	1	1833	
Side Brace	Zijklamp	402.10	4	965	
Side Brace	Zijklamp	402.15	2	1365	
SideBrace Splice	Zijklamp Verbinding	402.89	3	370	
Front Brace	Voorklamp	403.3EA	2	770	
Corner Gusset	Hoekinzetstuk	406	8	86	
Corner Gusset Stiffner	Versterking Van Hoekinzetstuk	407	2	150	
Anchor Bracket	Verankering Steun	407EA	2	69	
Left Hand Door Guide	Deurgeleider Linksbuiten	408409.3EA	2	933	
Side Beam	Zijbalk	501.10	2	1034	
Side Beam	Zijbalk	501.14	2	1234	
Roof Beam	Dakbalk	502.10	4	1034	
Roof Beam	Dakbalk	502.14	4	1234	
Ridge Cover	Nokplaat	503.02	1	615	
Ridge Cover	Nokplaat	503.03	1	415	
Ridge Cover	Nokplaat	503.07	1	490	
Ridge Cover	Nokplaat	503.08	1	690	
Roof Angle	Regengoot	504.01	2	1015	
Roof Angle	Regengoot	504.02	2	1365	
Left Hand Roof Beam Gusset	Linkersteunplaat Nokbalk	505	2	145	
Right Hand Roof Beam Gusset	Rechtersteunplaat Nokbalk	506	2	145	
Roof Beam Support	Nokbalk Steun	506.3	4	230	
Ridge Cover Cap	Nokplaat Eindstuk	507	2	160	
Left Hand End Cap	Eindkap Linker	5081	2	45	
Right Hand End Cap	Eindkap Rechte	5091	2	45	
Left Hand Door	Linkerdeur	601.29	1	1593	
Right Hand Door	Rechter deur	602.29	1	1593	
Door Track	Deurrail	603.63	2	1390	
Gable Brace	Geveltop-Klamp	603.18	4	1395	
Door Slider	Deurrolletje En Steun	6071	4	45	
Door Brace	Deurklamp	620.3	6	640	
Door Spacer	Deurhoekstuk	607EA	2	26	
Door Saddle	Deurslede	608.3EA	1	1226	
Door Handle	Deurhendel	609	2	100	
Door Pelmet	Verbinding Teil	615.02	1	1264	

LISTE DE PIECES	TEILE-LISTE	PART NO.	MOD LENGTH		
			107	MM	
DESCRIPTION DE LA PIECE	TEILE-BEZEICHNUNG				
Panneau Mural 600mm	600mm Wandplatten	101EA	12	1600	
Panneau D'angle	Eckplatten	103 EA	4	1600	
Panneau Mural 200mm	200mm Wandplatten	102EA	1	1600	
Montant De Porte	Türpfosten	106.29	2	1600	
Panneau Toit (Milieu)	Dach-Zwischenplatten	201.3	2	1520	
Panneau Toit (Milieu) 200mm	Dach-Zwischenplatten 200mm	202.3	4	1520	
Panneau Toit Avant Gauche/Arrière Droite	Linke Vordere Bzw. Hintere Rechte Dachplatte	203.29	2	1520	
Panneau Toit Avant Droite/Arrière Gauche	Rechte Vordere Bzw. Hintere Linke Dachplatte	204.29	2	1520	
Pignon-Avant Gauche/Arrière Droite	Giebel-Vorne Links Bzw. Hinten Rechts	301	2	920	
Pignon-Avant Droite/Arrière Gauche	Giebel-Vorne Rechts Bzw. Hinten Links	302	2	920	
Pignons Centraux	Mittel-Giebel	305.3	2	995	
Rail Base	Grundleiste	401.10	2	1033	
Rail Base	Grundleiste	401.14	3	1233	
Rail Base	Grundleiste	401.2	1	1833	
Cornières Latéral	Seitenstütze	402.10	4	965	
Cornières Latéral	Seitenstütze	402.15	2	1365	
Jonction Cornières Latéél	Seitenstütze Verbindung	402.89	3	370	
Cornières Avant	Vorderstütze	403.3EA	2	770	
Renfort D'angle Arrière	Hintere Eckenwinkel	406	8	86	
Kit D'ancrage	Eckenwinkelversteifung	407	2	150	
Piece D'ancrage	Verankerung Teil	407EA	2	69	
Guide De Porte Extérieur Gauche	Linke äußere Türführung	408409.3EA	2	933	
Poutre Latérale	Seitenträger	501.10	2	1034	
Poutre Latérale	Seitenträger	501.14	2	1234	
Poutre Toit	Dachträger	502.10	4	1034	
Poutre Toit	Dachträger	502.14	4	1234	
Faîtière	Firstverkleidung	503.02	1	615	
Faîtière	Firstverkleidung	503.03	1	415	
Faîtière	Firstverkleidung	503.07	1	490	
Faîtière	Firstverkleidung	503.08	1	690	
Gouttière d,angle	Dachtraufeverkleidung	504.01	2	1015	
Gouttière d,angle	Dachtraufeverkleidung	504.02	2	1365	
Gousset De Poutre Faîtière Gauche	Linke Firsträgerwinkel	505	2	145	
Gousset De Poutre Faîtière Droite	Rechte Firsträgerwinkel	506	2	145	
Soutien De Poutre Toit	Dachtragbalken	506.3	4	230	
Cache Plastique Toiture	Firstverkleidungskappe	507	2	160	
Embout D'Extrémité	Endkappen	5081	2	45	
Embout D'Extrémité	Endkappen	5091	2	45	
Porte Gauche	Linke Tür	601.29	1	1593	
Porte Droite	Rechte tür	602.29	1	1593	
Glissière De Porte	Türschienen	603.63	2	1390	
Glissière De Pignon	Giebel-Vorne Balken	603.18	4	1395	
Coullissiere De Porte	Türrollen & Befestigungsteil	6071	4	30	
Porte Renforcee	Türstütze	620.3	6	640	
Bride de Porte	Tür-Distanzschiebe	607EA	2	26	
Bride De Porte	Türschwelle	608.3EA	1	1226	
Poignée De Porte	Türgriff	609	2	127	
Pièce de Jonction	Türrandabdeckung	61502	1	1264	

WALL PANEL PANNEAU MURAL WANDPLATTEN WANDPANEEL



101

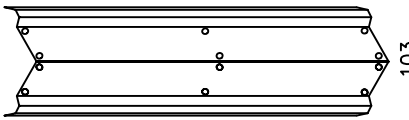

103

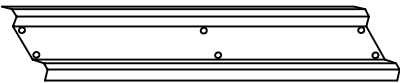

102

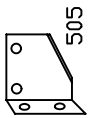

505

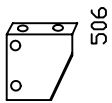

506

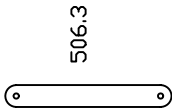

506.3

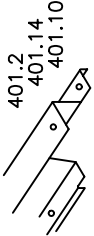

401.2
401.14
401.10

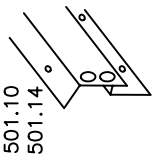

501.10
501.14

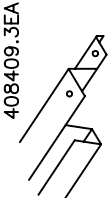

408409.3EA

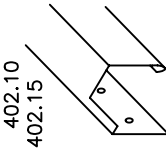

402.10
402.15

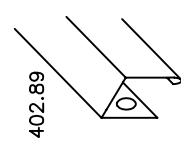

402.89

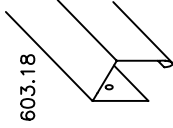

603.18

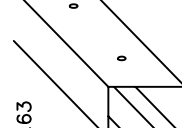

603.63

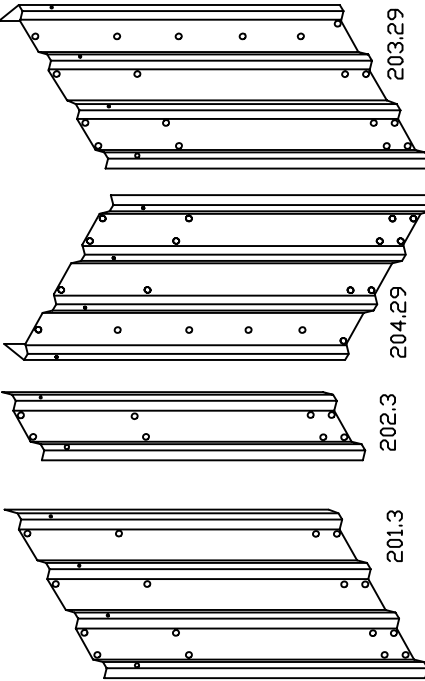

201.3

202.3

204.29

203.29

ROOF PANEL PANNEAU TOIT DACHPLATTE DAKPLAAT

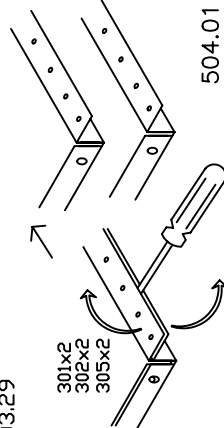

301x2

302x2

305x2

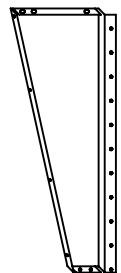

302 x 2

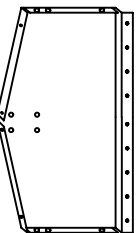

305.3 x 2

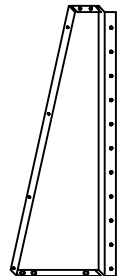

301 x 2

GABLES ARE PACKED IN PAIRS
TAKE APART WITH CARE

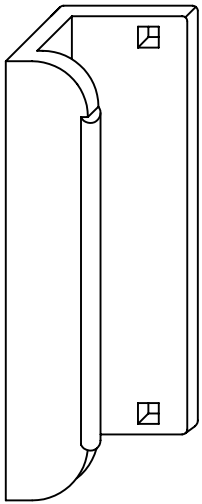

609 x 2

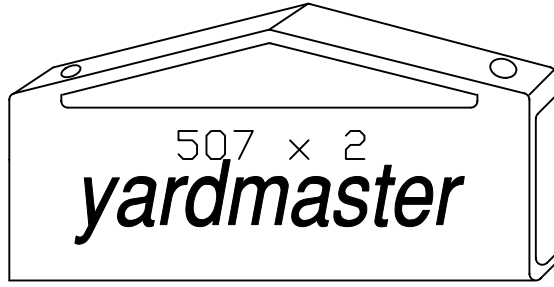

507 x 2
yardmaster

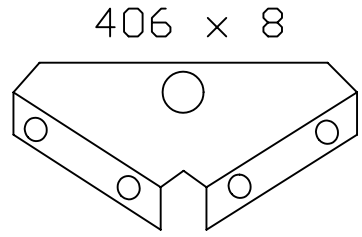

406 x 8

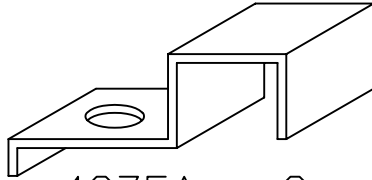

407EA x 2

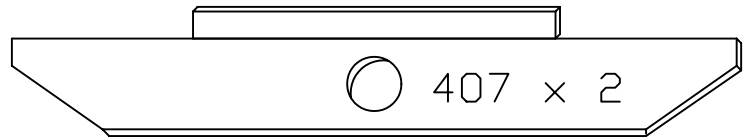

407 x 2

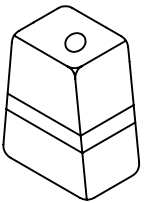

5081 x 2

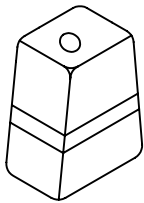

5091 x 2

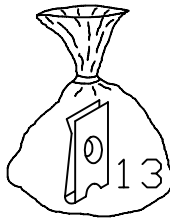

13



10

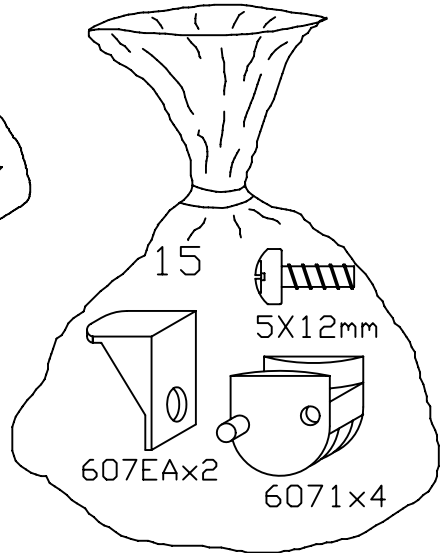

15

5X12mm

607EAx2

6071x4

12x4mm

11x4mm

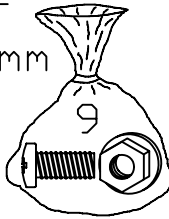

9

M5X12mm



14

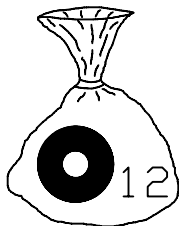

12

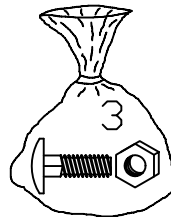

3

12X5mm X 4

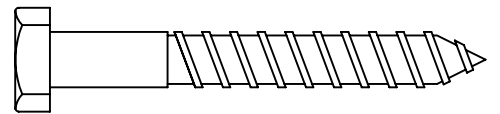

M8X50mm X 2



5

8X9mm

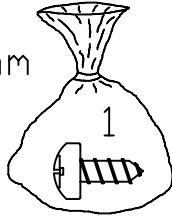

1

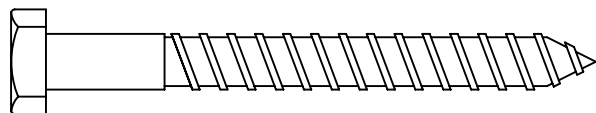

M8X70mm X 2

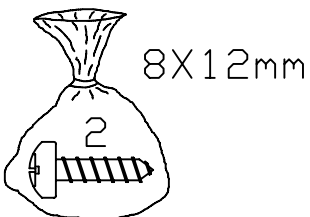

2

8X12mm

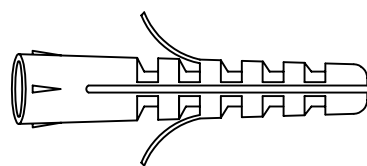

M10X50mm X 4

M8X19mm X 4

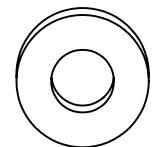

ASSEMBLY INSTRUCTIONS

Before starting, read through the assembly instructions carefully. Check thoroughly all the parts you have received against the parts list (page 1) and the diagram (page 3,4). Ensure that no parts are damaged.

THINGS TO REMEMBER !

- 1. WEATHER WARNING ! DO NOT ERECT YOUR BUILDING ON A WINDY DAY. ANY BUILDING LEFT PARTIALLY CONSTRUCTED MAY BE SERIOUSLY DAMAGED (FIG.1).**
- 2. ALWAYS ASSEMBLE THE ROOF FIRST ESPECIALLY IF YOU DO NOT INTEND TO COMPLETE CONSTRUCTION ON THE SAME DAY.**
- 3. ALL ASSEMBLY OPERATIONS MUST TAKE PLACE ON A COMPLETELY LEVEL SURFACE (FIG. 1)**
- 4. UNLESS OTHERWISE STATED SCREWS AND FIBRE WASHERS (BAGS 1 AND 12) MUST BE USED IN ALL ASSEMBLY OPERATIONS.**
- 5. IT IS RECOMMENDED THAT YOU WEAR THE GLOVES PROVIDED WHEN ASSEMBLING THIS PRODUCT.**
- 6. THE SHED SHOULD BE SECURELY ANCHORED TO A FIRM LEVEL BASE EG CONCRETE, PAVING SLABS, WOOD ETC FOR CONCRETE BASE SEE BELOW.**

SITE PREPARATION CONCRETE.

1. Concrete should be laid a minimum of 75mm thick and at least 100mm greater than the overall size of the metal base frame at approx. 25mm above ground level. A sheet of heavy duty polythene placed under the base area will help prevent dampness rising from the ground into the shed. For concrete base measurements see fig. 2.

NOTICE DE MONTAGE

Avant de commencer à lire attentivement la notice de montage, vérifiez précisément si vous avez bien reçu toutes les pièces énoncées sur la liste page 2, ainsi que sur le schéma page 3&4. Assurez vous qu'aucune pièce n'a été endommagée.

N'OUBLIEZ PAS !

- 1. TEMPÊTE DE VENT: NE JAMAIS MONTER VOTRE ABRI PAR GRAND VENT. NE PAS LAISSER UN ABRI PARTIELLEMENT MONTÉ, LES PIÈCES POUVANT ÊTRE ENDOMMAGÉES (FIG. 1).**

2. ASSEMBLER EN PRIORITÉ LE TOIT SURTOUT SI VOUS PENSEZ NE PAS FINIR LE MONTAGE DANS LA JOURNÉE.

3. TOUTES LES OPÉRATIONS DE MONTAGE DOIVENT ÊTRE RÉALISÉES SUR UNE SURFACE PLANE (fig 1).

4. UTILISER SUR TOUTES LES VIS À MÉTAUX D'ASSEMBLAGE (SAC NO 1) LES RONDELLES D'ÉTANCHÉITÉ EN FIBRE (SAC NO 12).

5. L'ABRI DOIT ÊTRE FIXE AU SOL SUR UNE SURFACE PLANE, PAR EXEMPLE, BÉTON, DALLES EN BÉTON, BOIS ETC. POUR UNE SURFACE DE BÉTON, VOIR CI-DESSUS.

PRÉPARATION DE LA DALLE:

1. Le béton doit être coulé sur une épaisseur de 75mm, et dépasser de 100mm la hauteur du profilé de base soit 25mm au dessus du niveau du sol. L'utilisation d'une toile de polythène épaisse et résistante, placée sous la base aidera à empêcher l'humidité de monter du sol dans l'abri. Pour les dimensions de la dalle en béton, vous reporter à la fig. 2.

MODELLE MONTAGEANLEITUNG

VOR BEGINN:

1. Machen Sie sich mit den Montageanweisungen vertraut.
2. Überzeugen Sie sich an Hand der Teileliste (Seite 2) und der Schaubilder (seite 3 &4), ob alles vollständig ist und die Teile nicht beschädigt sind.

WICHTIG

- 1. STELLEN SIE DAS HAUS NICHT AN EINEM STÜRMISCHEN TAG AUF. JEDES HAUS WÜRDE UNTER SOLCHEN WETTERBEDINGUNGEN BESCHÄDIGT WORDEN.**
- 2. DER GARTENSCHUPPEN MUß AUF EINER VOLLSTÄNDIG EBENEN FLÄCHE ERRICHTET WERDEN.**
- 3. SOFERN NICHT ANDERS ANGEZEIGT BENÜTZEN SIE DIE SCHRAUBEN UND WASSERDICHTEN FASERSCHEIBEN (BEUTEL 1 & 12) BEI ALLEN MONTAGEGÄNGEN.**
- 4. TRAGEN SIE DIE BELIEFERTEN HANDSCHUHE BEI DER MONTAGE.**

VORBEREITUNG DES BETONFUNDAMENTS:

Die Betonplattform soll mindestens 70-80mm stark und mindestens 100mm länger und breiter als der metall-grundrahmen sein. die

plattform sollte außerdem mindestens 25mm über dem boden sein. Ein laken aus hochleistungskunststoff unter dem fundament wird dazu helfen, feuchtigkeit vorzubeugen, die von der erde in den schuppen hineindringt.

BOUWHANDLEIDING MODELLEN

Voordat U met de bouw begint, maakt U zich dan eerst goed vertrouwd met de bouwaanwijzingen. Kruis alle ontvangen onderdelen op de onderdelenlijst (pagina 1) en diagram (pagina 3&4) aan. Controleer of de onderdelen niet zijn beschadigd.

BELANGRIJK !

1 MONTEER UW SCHUUR NIET OP EEN WINDERIGE DAG. DE KANS DAT ER TÏDENS HET MONTEREN BESCHADIGINGEN ONTSTAAN IS DAN ZEER GROOT AANWEZIG (Afb 1).

2 HET IS AAN TE RADEN , OM EERST HET DAK TE MONTEREN, VOORAL ALS U NIET VAN PLAN BENT OM HET COMPLETE SCHUURTJE IN EIN DAG TE MONTEREN.

3 DE BOUW DIENT UITGEVOERD TE WORDEN OP EEN GEHEEL VLAkke ONDERGROND (Afb 1)
4 TENZY ANDERS AANGEGEVEN MOETEN BIJ HET MONTEREN DE SCHROEVEN EN VEZELRINGEN UIT (Zak 1 en 12) WORDEN GEBR UIKT.

VOORBEREIDING VAN DE BOUWPLAATS VAN BETON

1 Het beton dient minimaal 75mm dik te worden gelegd. Ongeveer 25mm boven grondniveau dient het beton minstens 100mm breder te zijn dan de totale maal van het metalen funderingsraam.
Afb. 2.

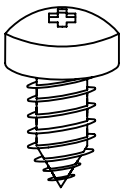

WASHERS TO BE USED ON ALL SCREWS
 VEZELRINGEN VOOR GEBRUIK ONDER ALLE SCHROEVEN
 RONDELLES POUR TOUTES LES VIS

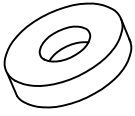

FASER SCHEIBEN FÜR VERWENDUNG MIT ALLEN SCHRAUBEN
 ARANDELAS QUE DEBEN USARSE CON TODOS LOS TORNILLOS
 ANILHAS PARA SEREM UTILIZADAS EM TODOSMOS PARAFUSOS

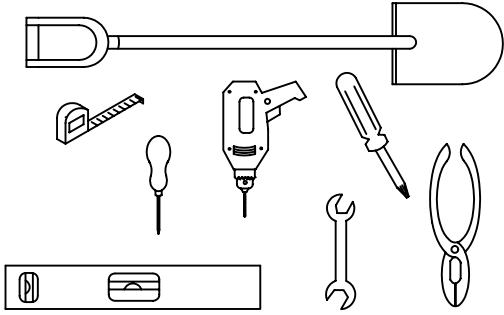
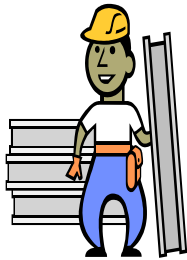
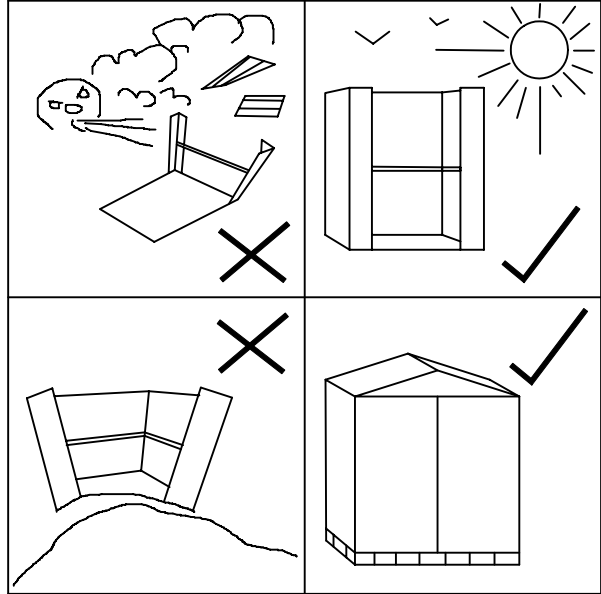

FIG. 1



X 2

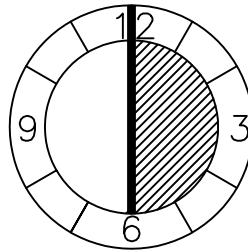
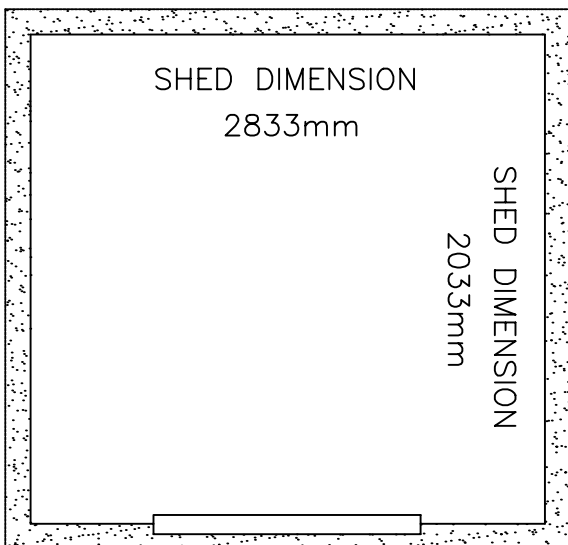

FIG. 2

BASE DIMENSION 3000mm



BASE DIMENSION
2180mm

FRONT DEVANT FRENTE
 VOORKANT VORDERSEITE

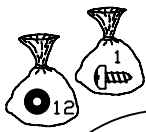

Overlap 401.14 and 401.2 To Make Up Back Base Rail
CHEVAUCHER 401.14 ET 401.2 POUR FAIRE RAIL BASE ARRIERE

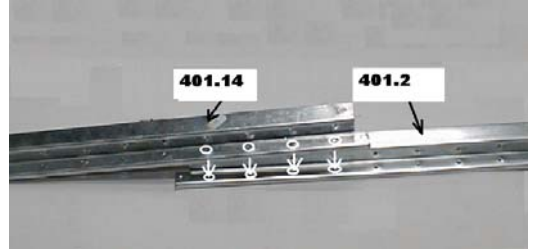
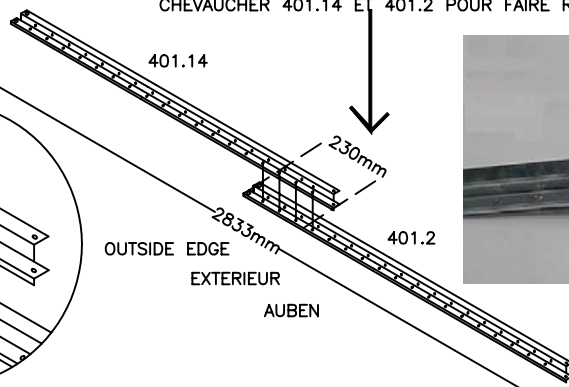

OUTSIDE EDGE
EXTERIEUR
AUBEN

Overlap by 4 Holes As Shown
CHEVAUCHER PAR 4 TROUS COMME INDIQUE

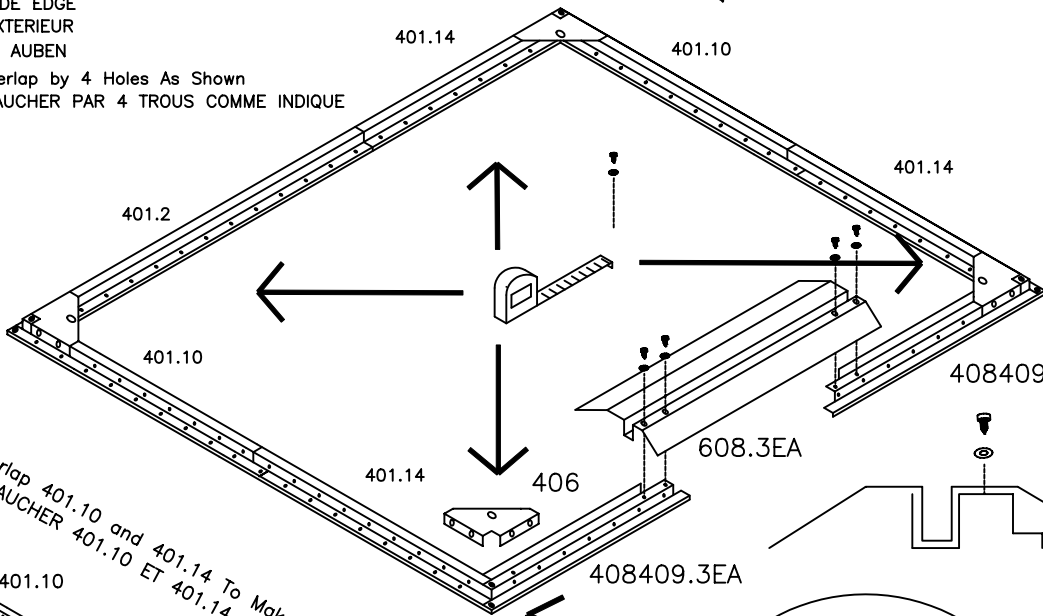

FRONT
VOORKANT
DEVANT
VORDERSEITE
FRENTE

EXTERIEUR
AUBEN
OUTSIDE

Overlap 401.10 and 401.14 To Make Up Side Base Rail
CHEVAUCHER 401.10 ET 401.14 POUR FAIRE RAIL BASE LATERALE

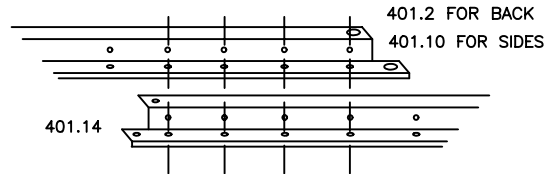
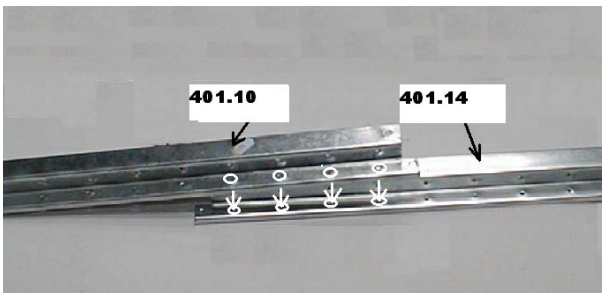
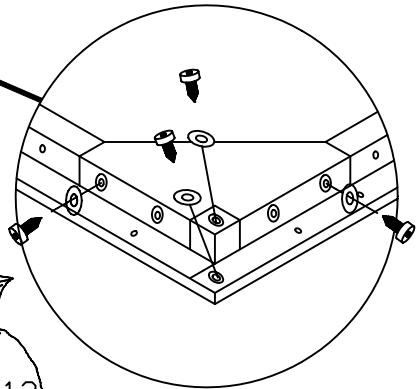
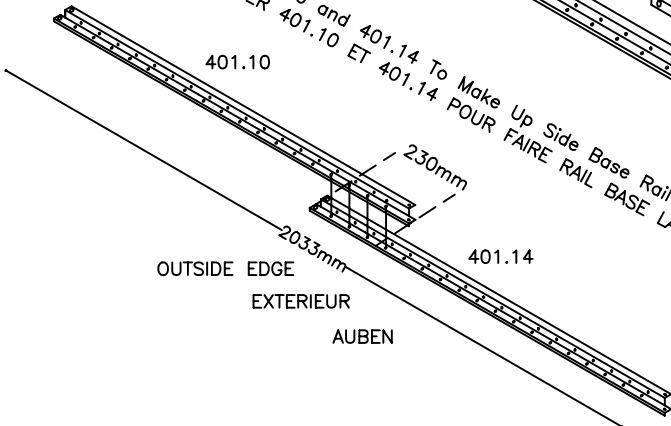

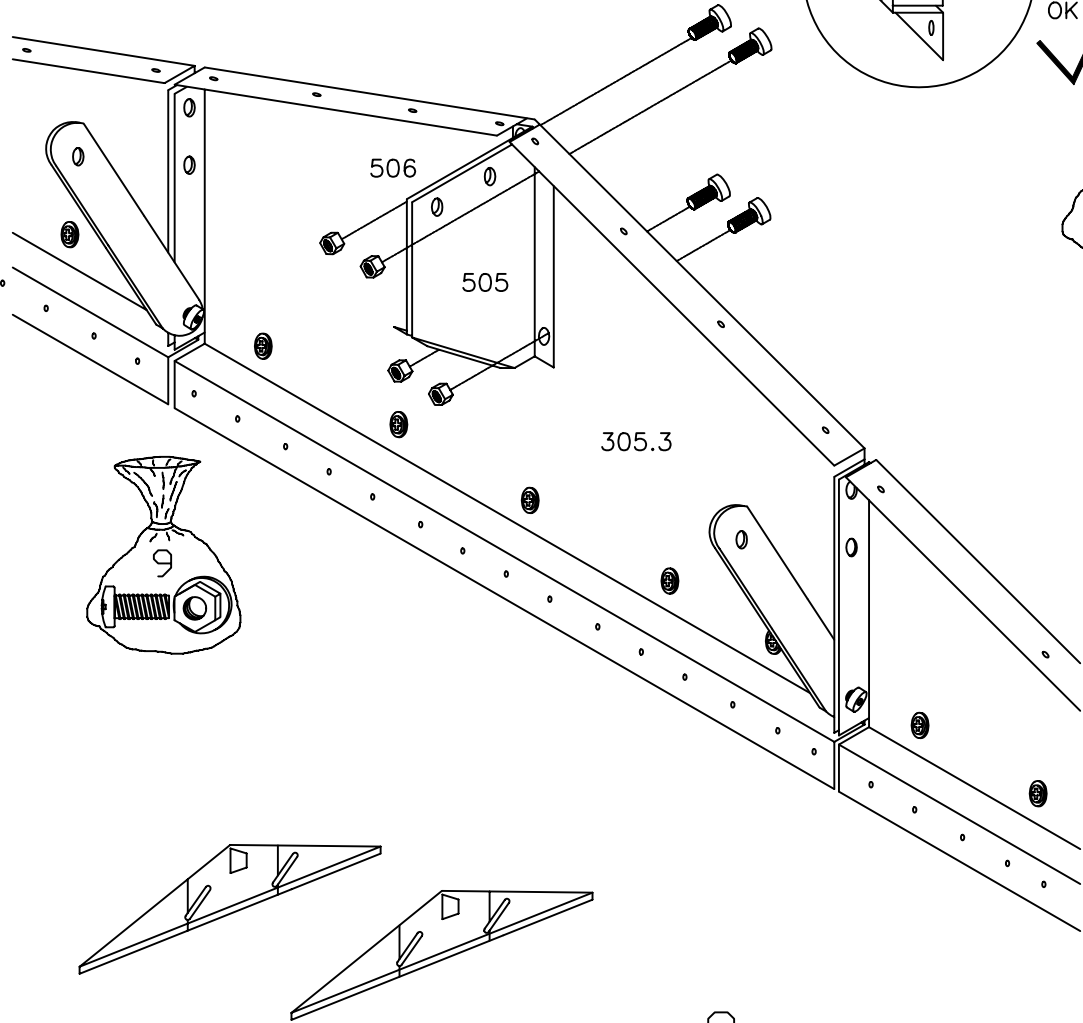
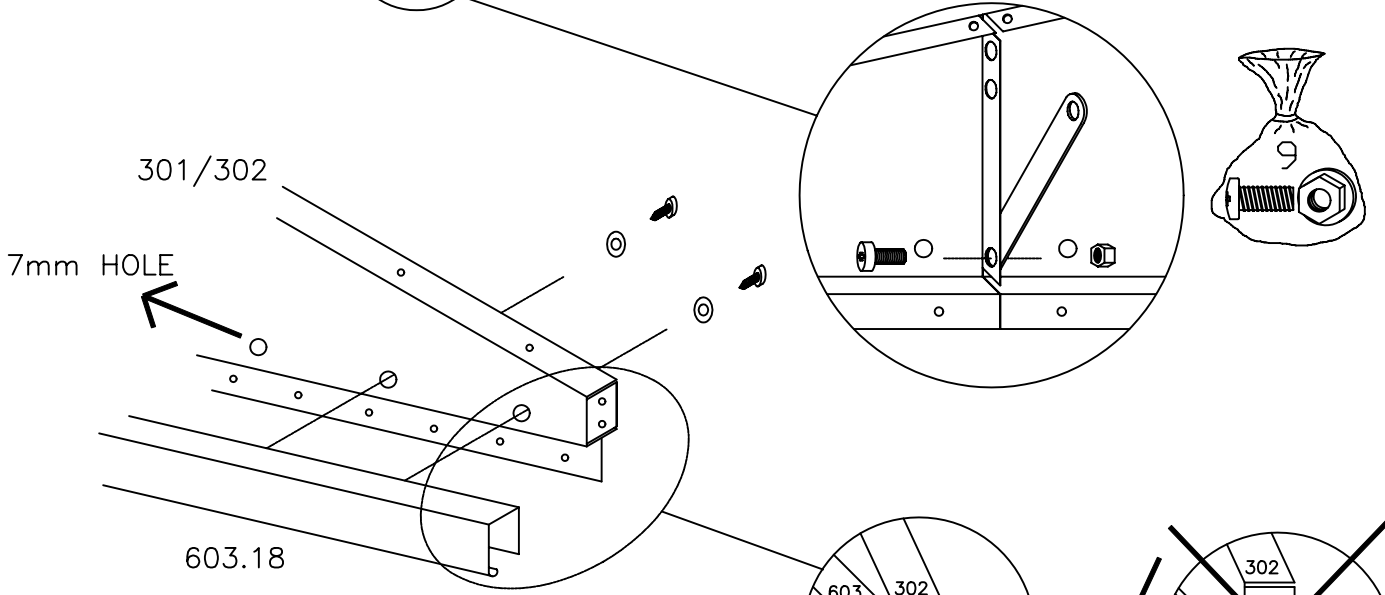
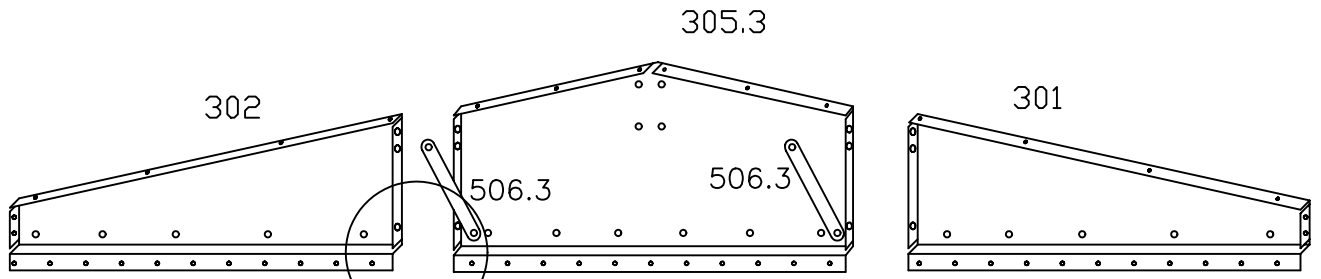

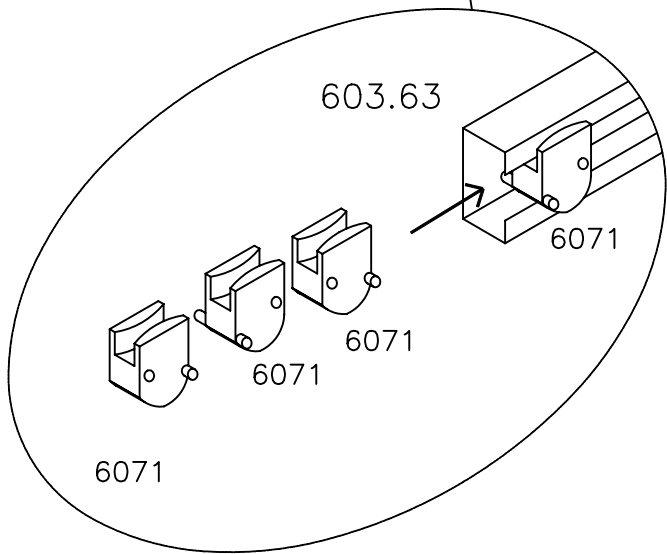
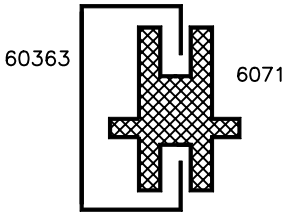
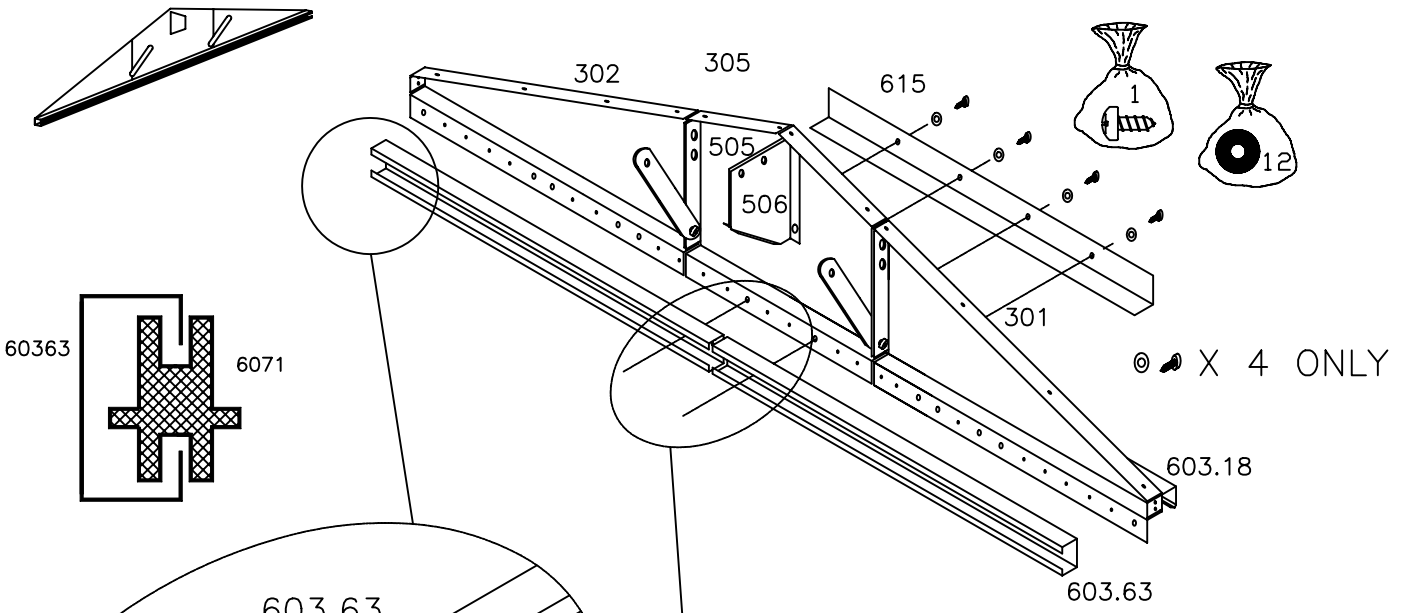

FRONT GABLES
 GEVELTOP-VOORKANT
 FACHADA FRONTAL
 PIGNON-AVANT
 GIEBEL-VORNE
 EMPENA FRONTAL

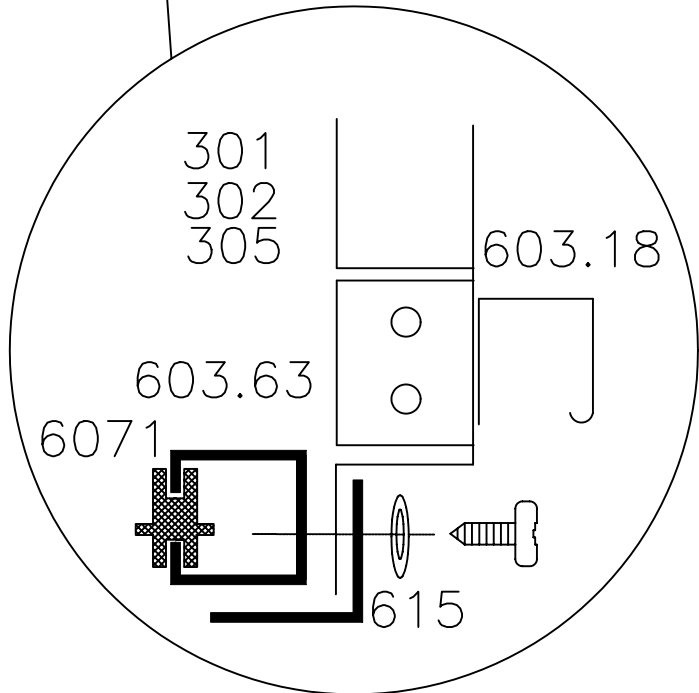
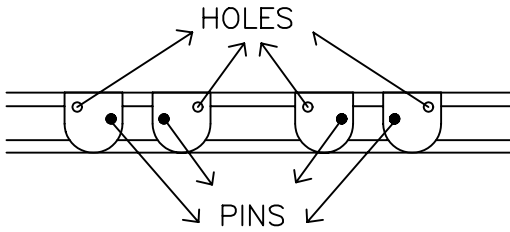

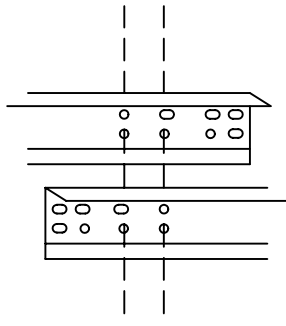

233 mm Overlap

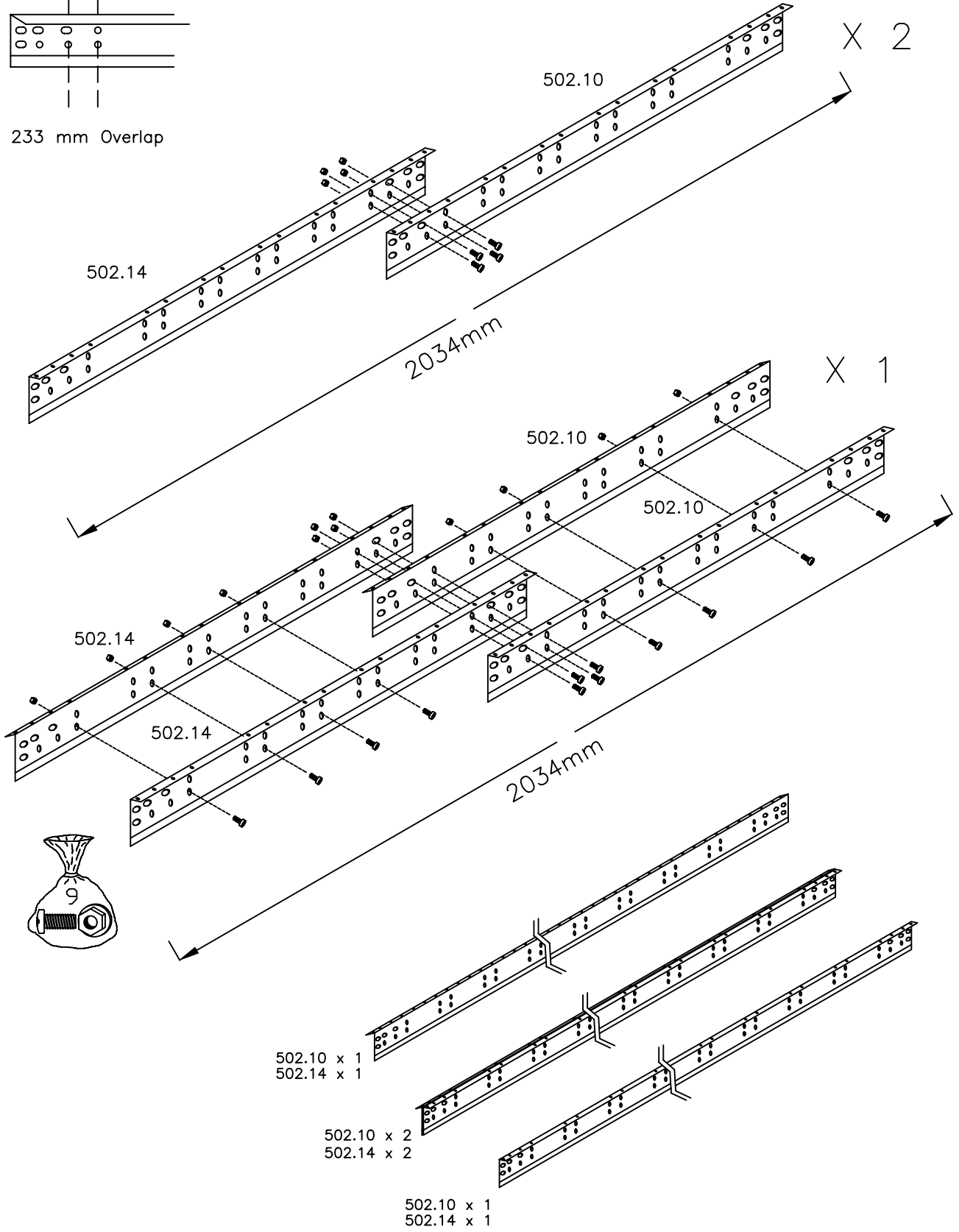
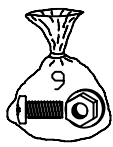

502.10 x 1
502.14 x 1

502.10 x 2
502.14 x 2

502.10 x 1
502.14 x 1

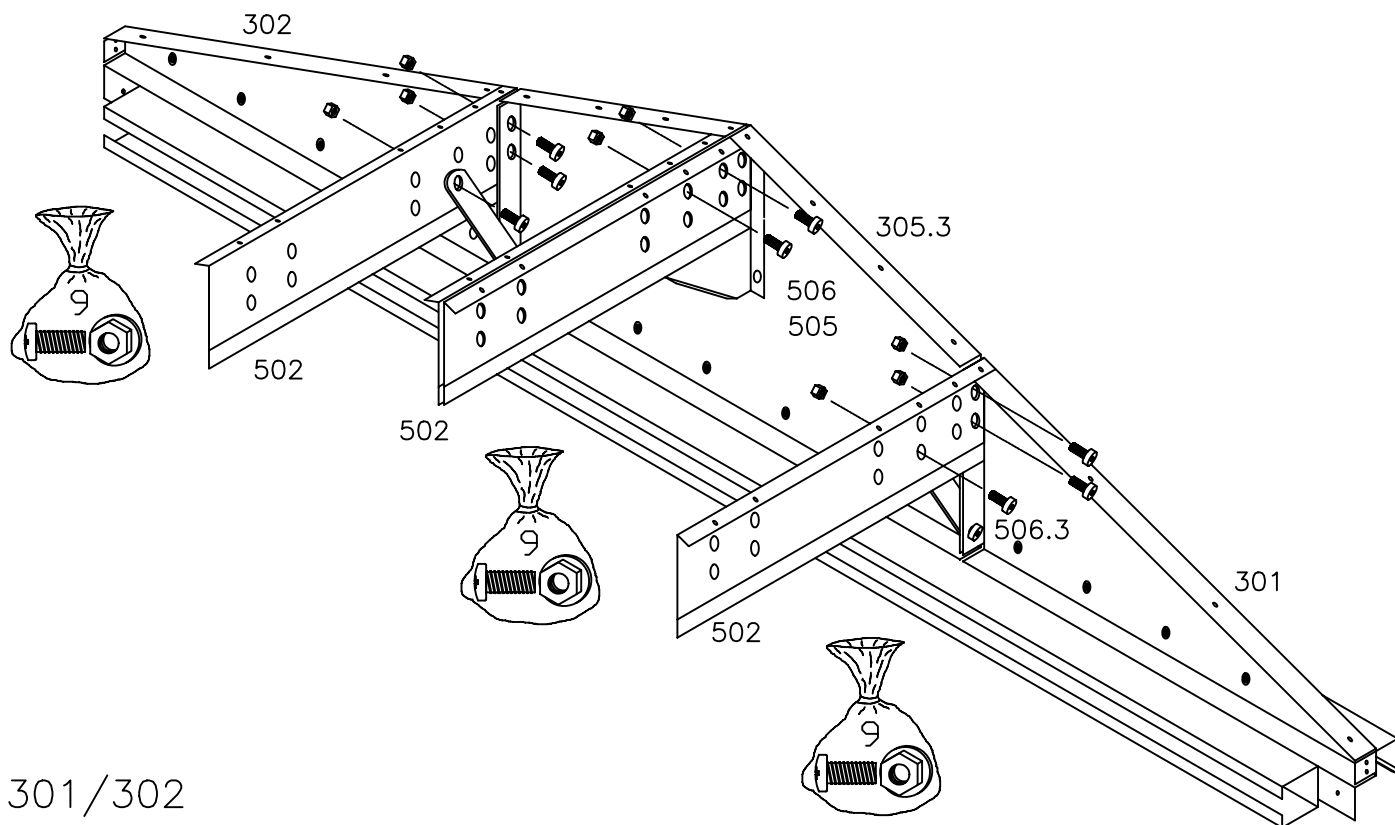

301/302

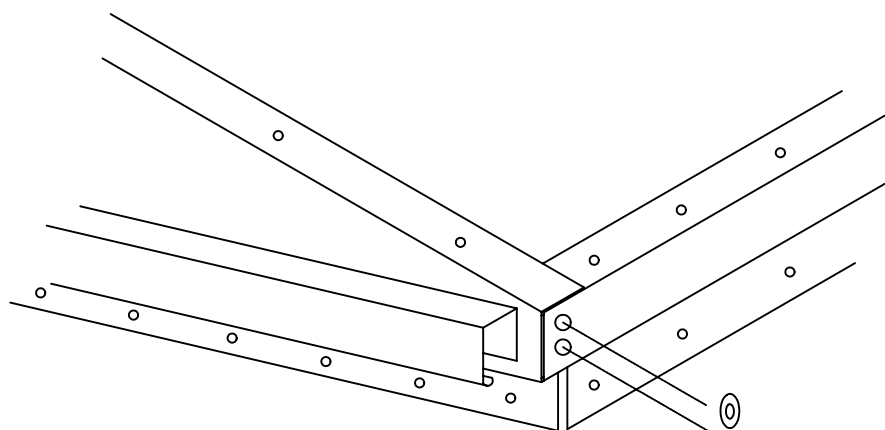

501

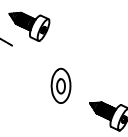
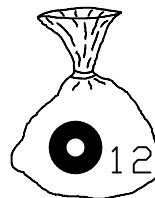

501.14

234mm Overlap

501.10

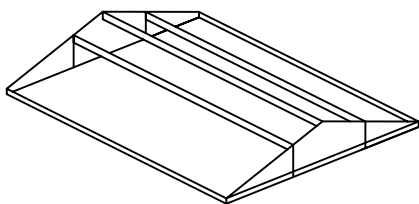
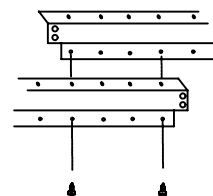
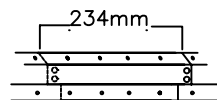
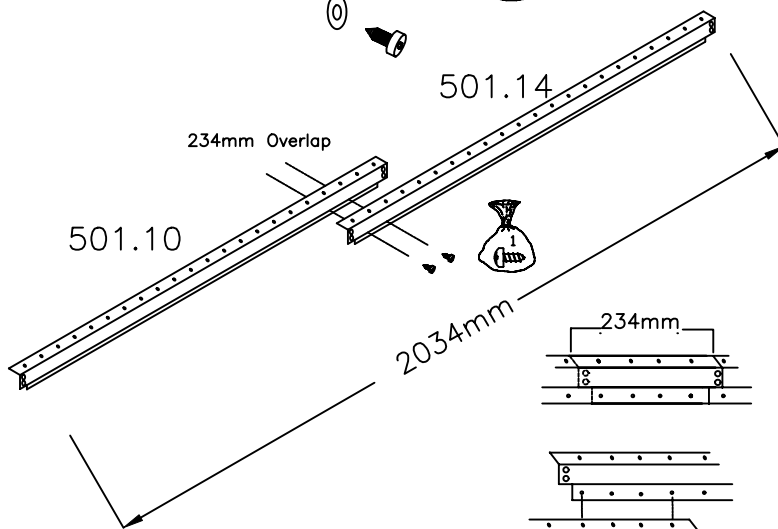

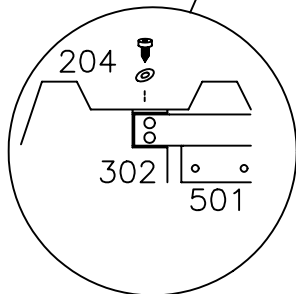
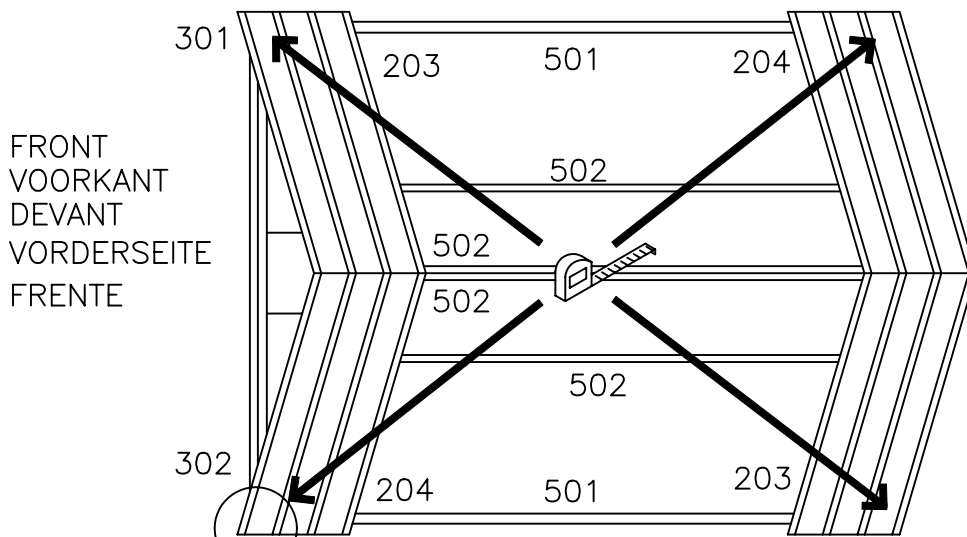
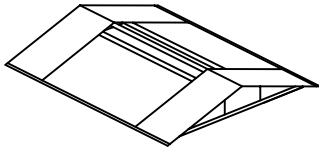
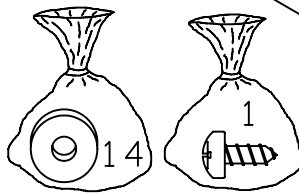
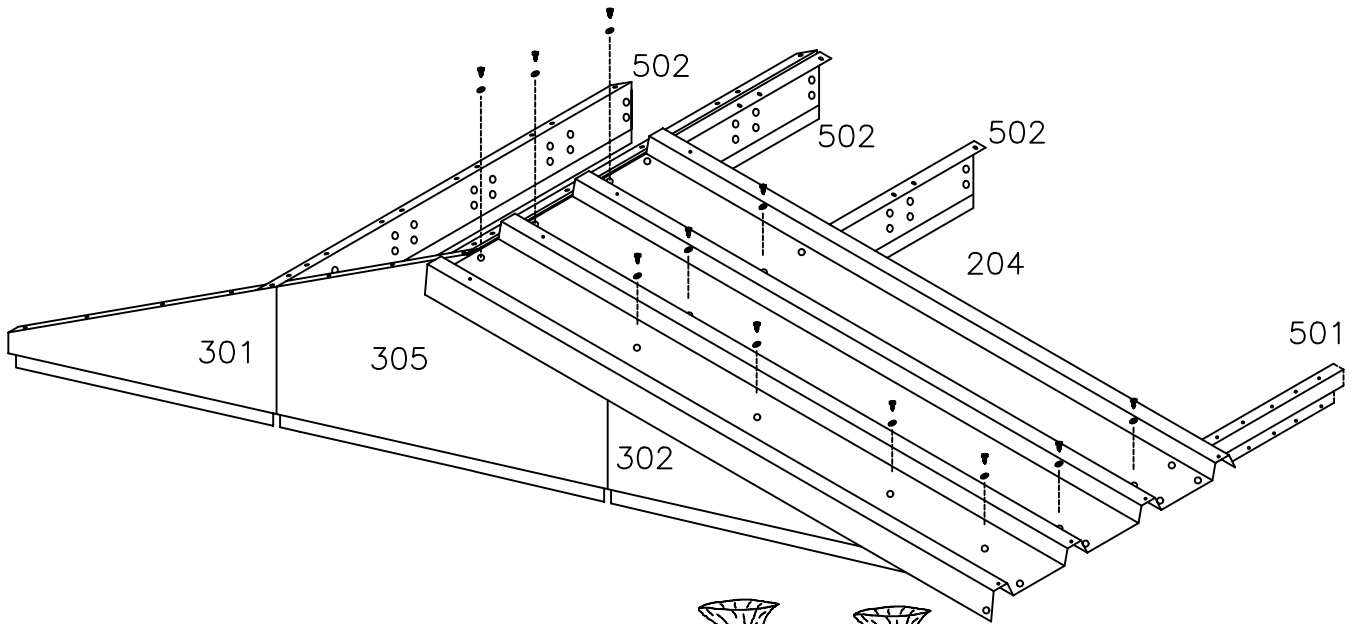

ENSURE ROOF FRAME
IS "SQUARE" BEFORE
SECURING PANELS

DACHRAHMEN RECHTWINKLIG
VOR DACHPLATTEN
FESTZUMACHEN

EQUARREZ LE METIER
AVANT DE FIXER
LES PANNEAUX

MODEL 107

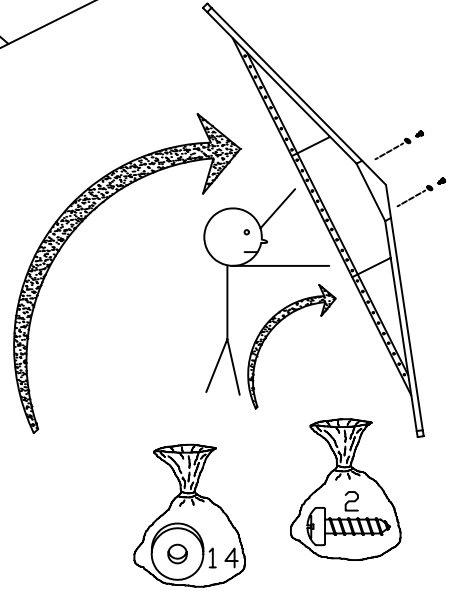
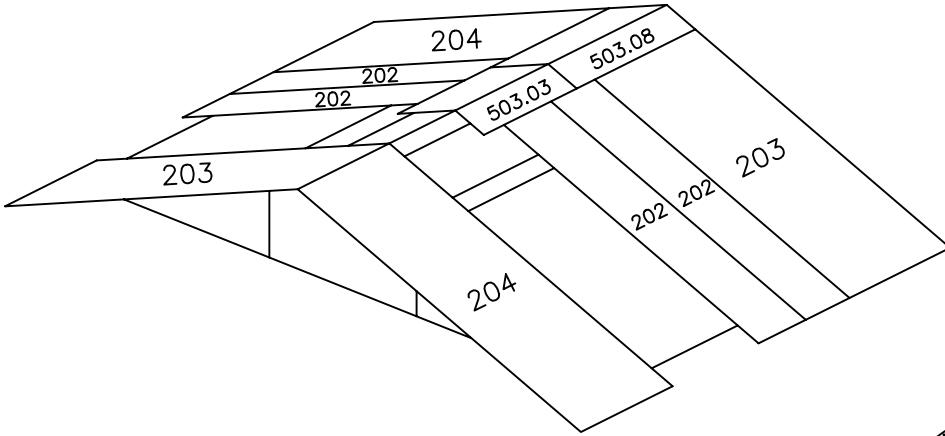

MODEL 107

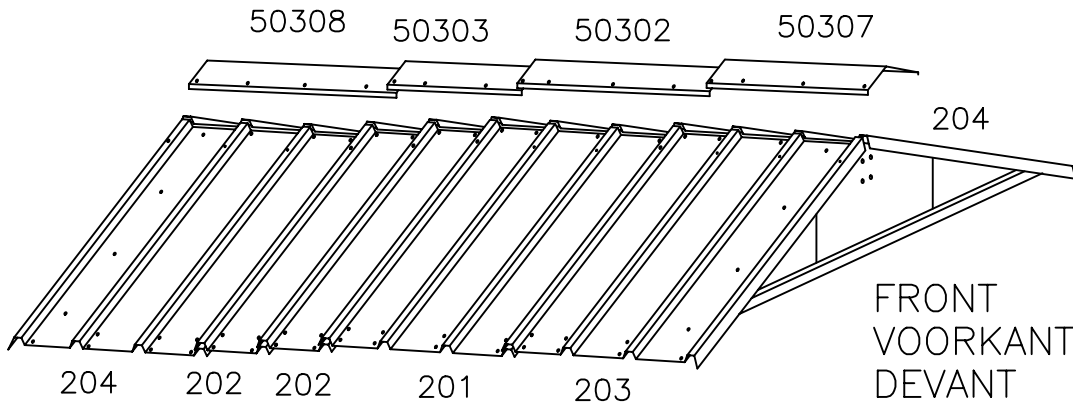

FRONT
 VOORKANT
 DEVANT
 VORDERSEITE
 FRENTE

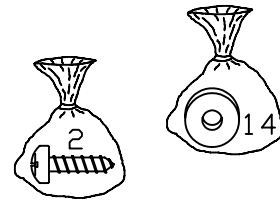
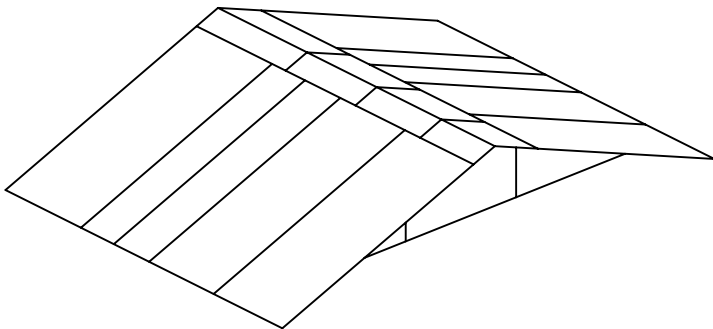

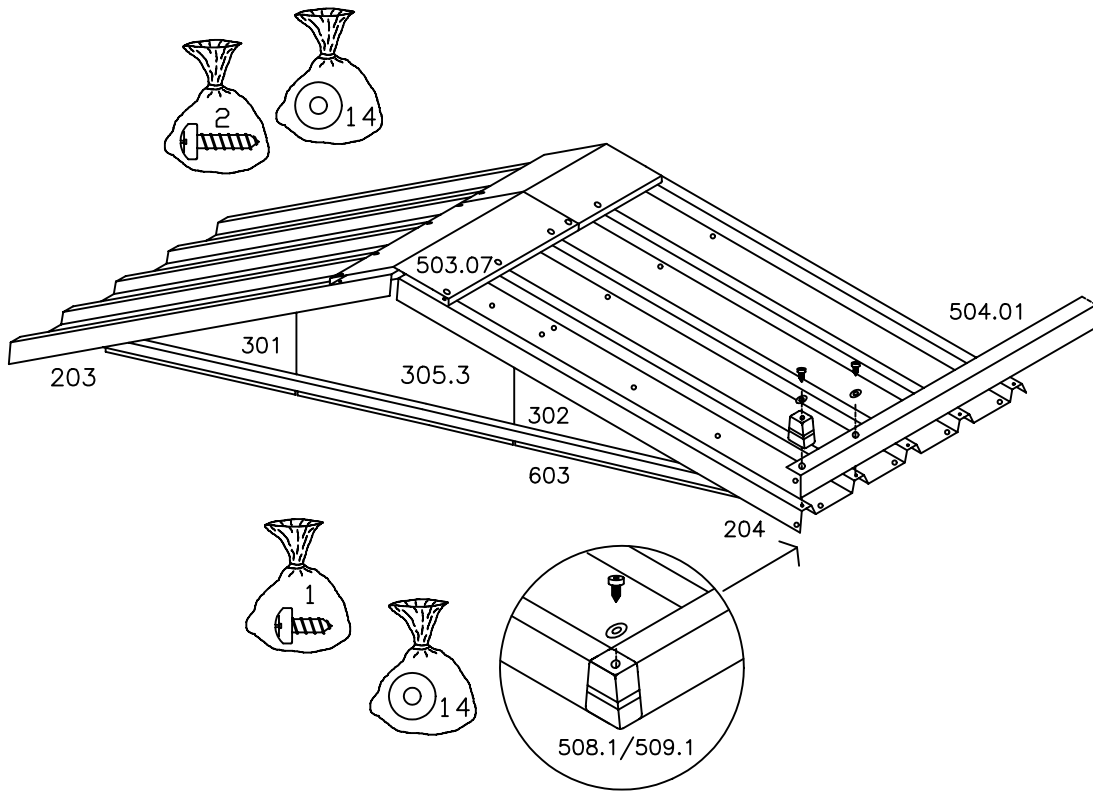

MODEL 107

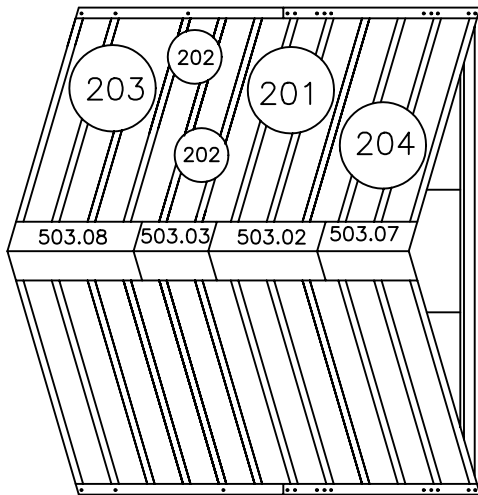

FRONT
 VOORKANT
 DEVANT
 VORDERSEITE
 FRENTE

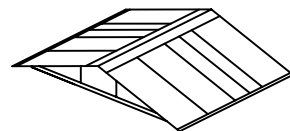
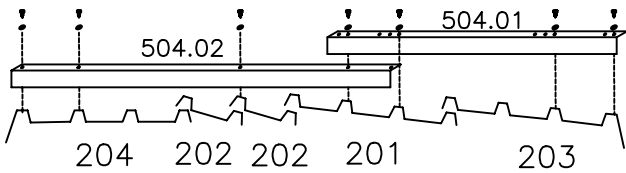

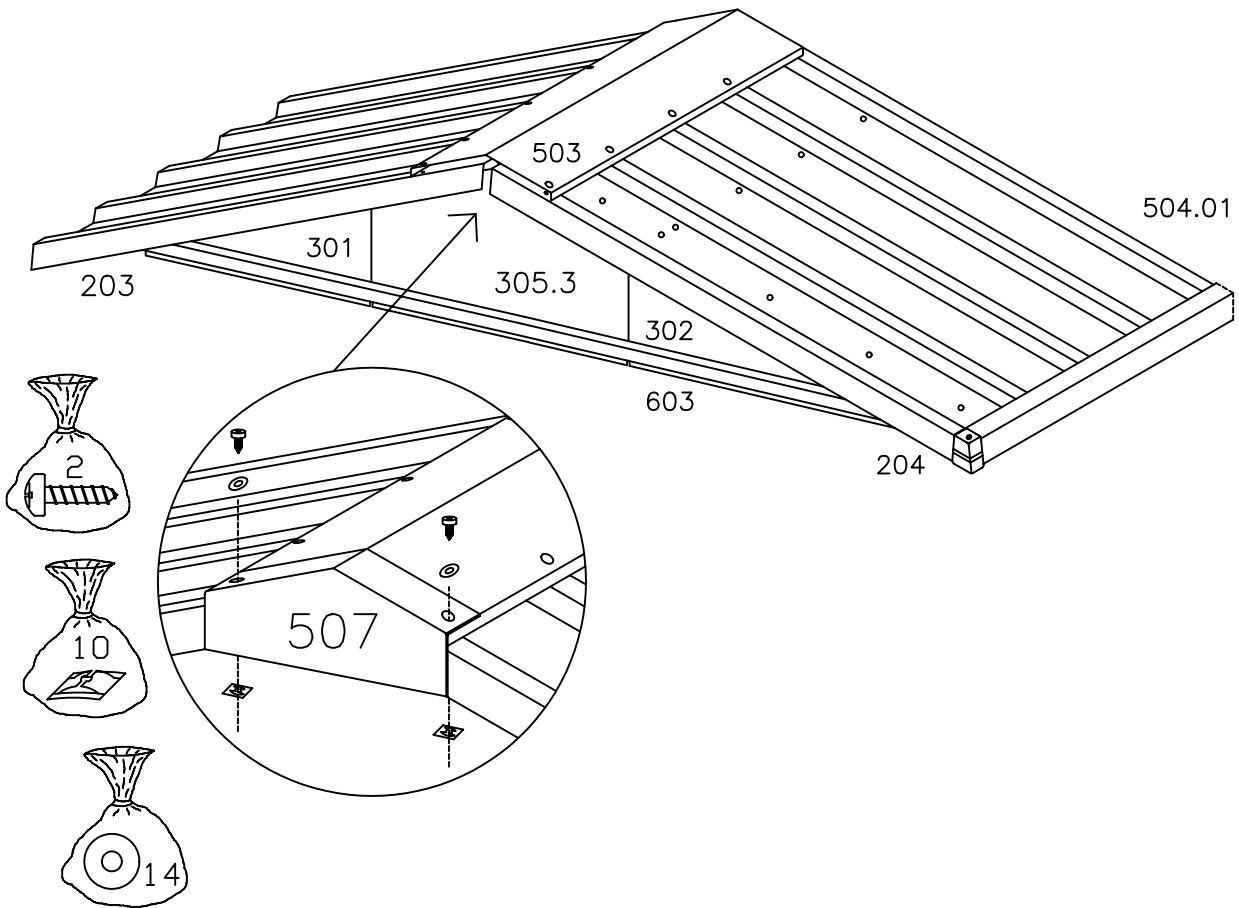

MODEL 107

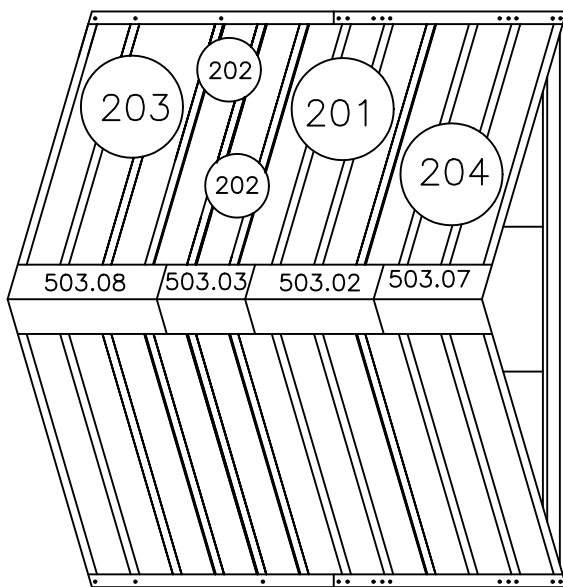

FRONT
 VOORKANT
 DEVANT
 VORDERSEITE
 FRENTE

BACK
402.89

402.15 ····· 402.15

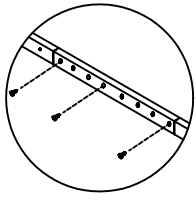

2765mm

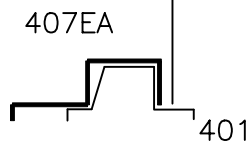
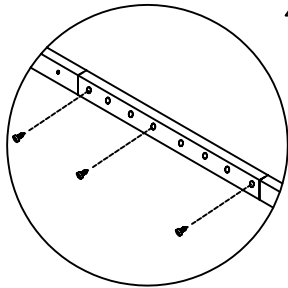
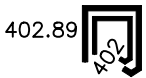
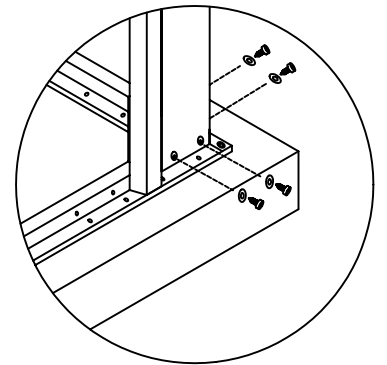
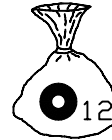
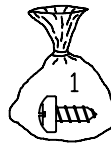
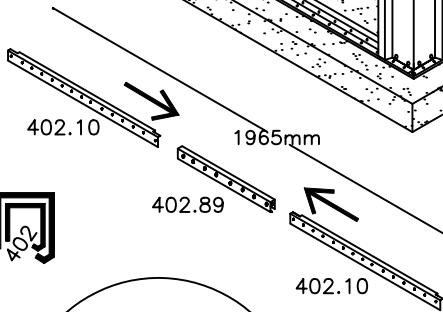
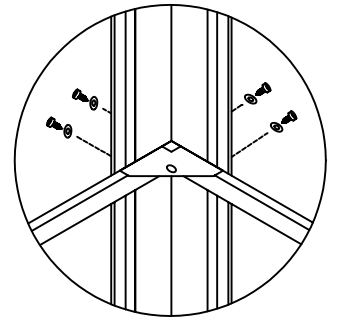
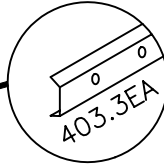
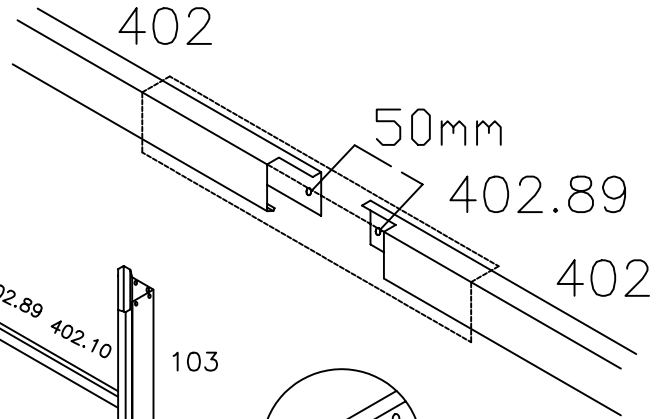
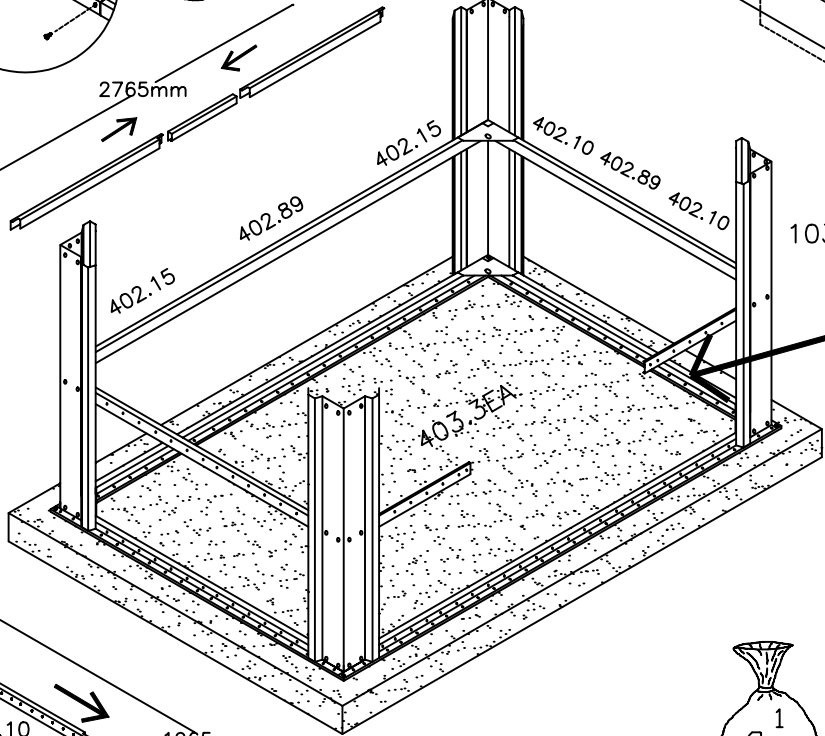

SIDES
402.89

402.10 ····· 402.10

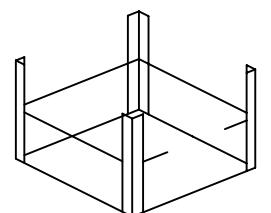
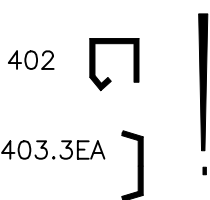
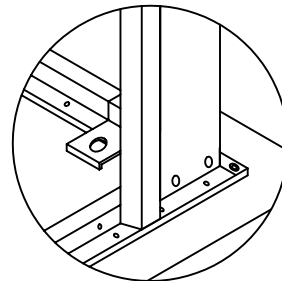

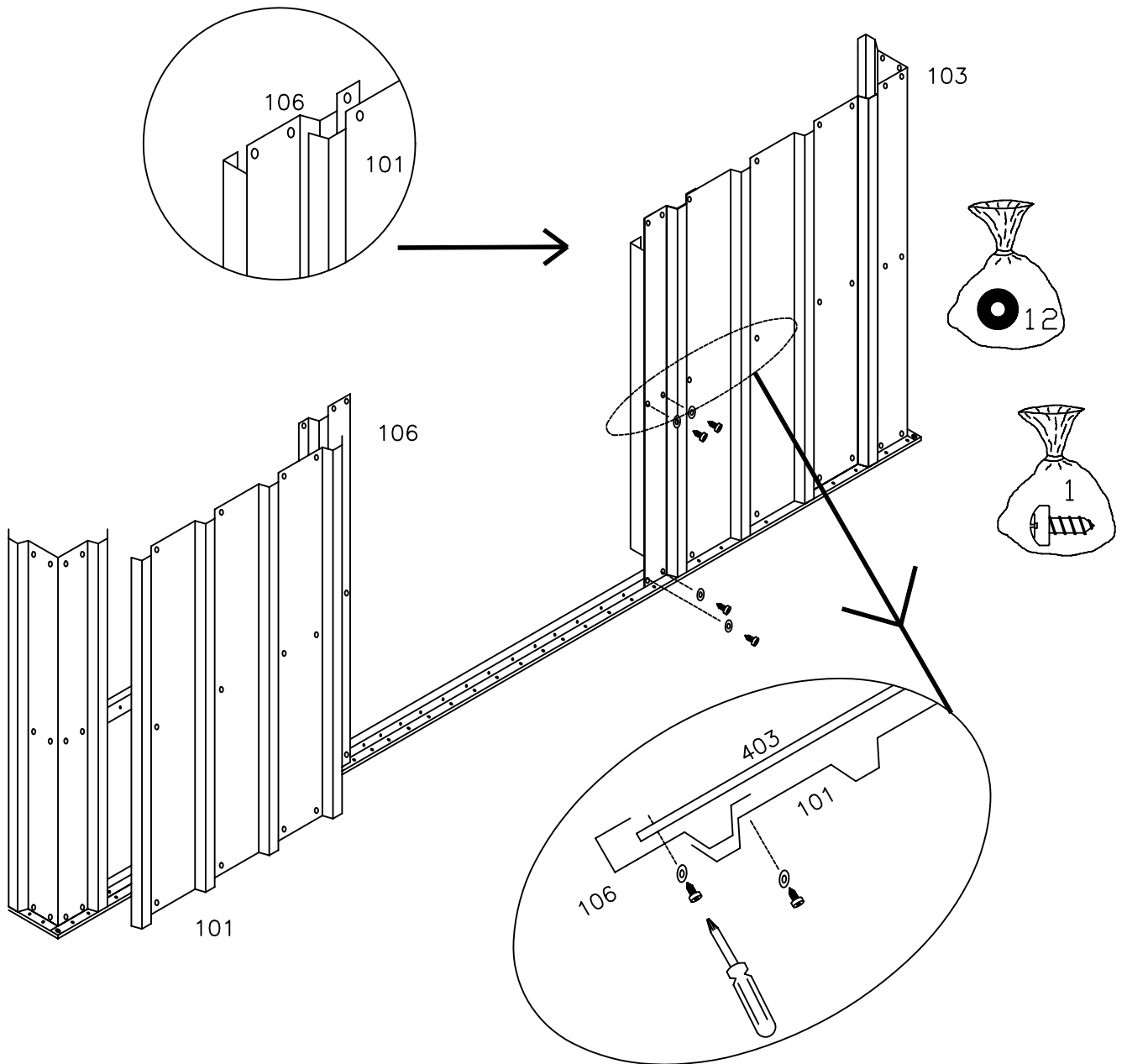

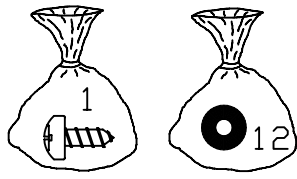

WALL PANEL ASSEMBLY
 MONTEREN VAN WANDPANEEL
 MONTAGE DE LA PANNEAU MURAL
 WANDPLATTEN MONTAGE
 PAINEL DA PAREDE
 PANELES DE LA PARED

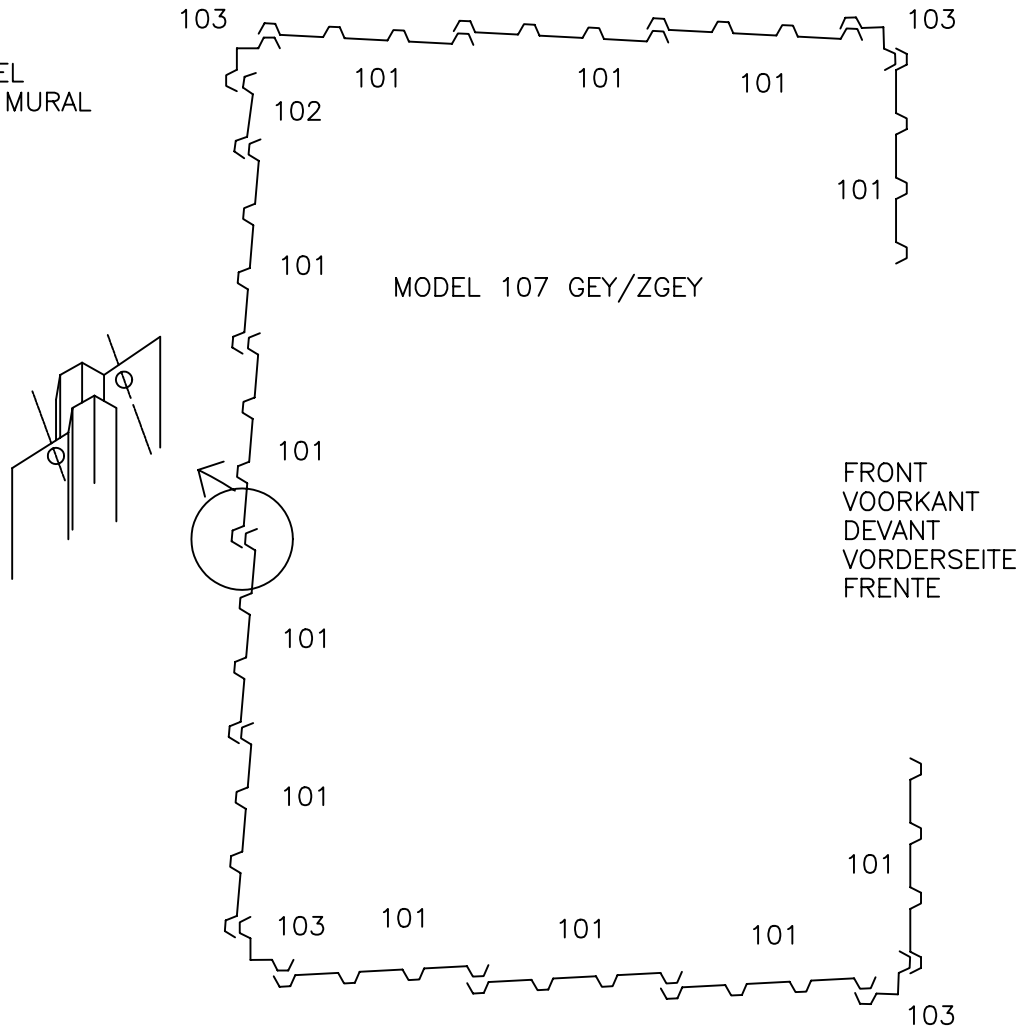

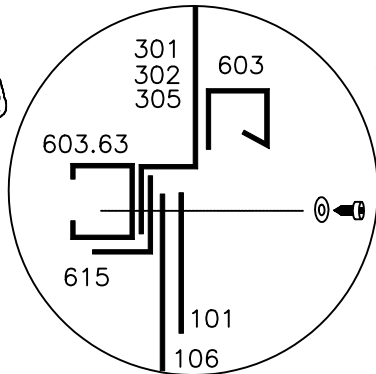
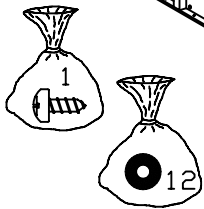
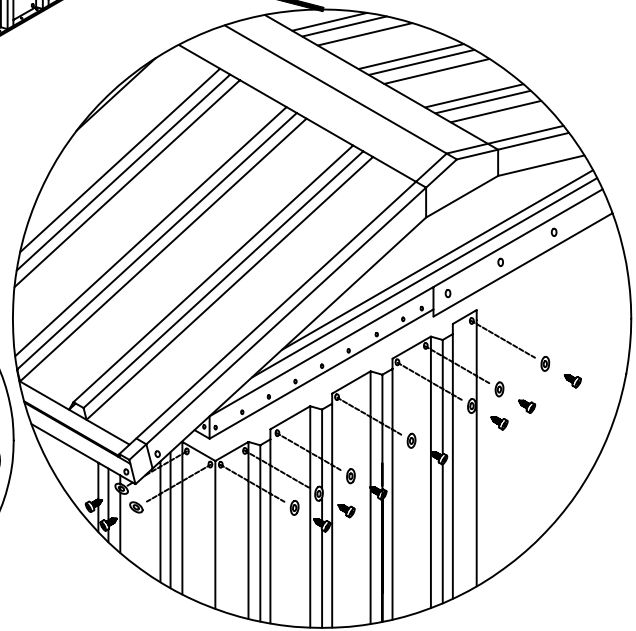
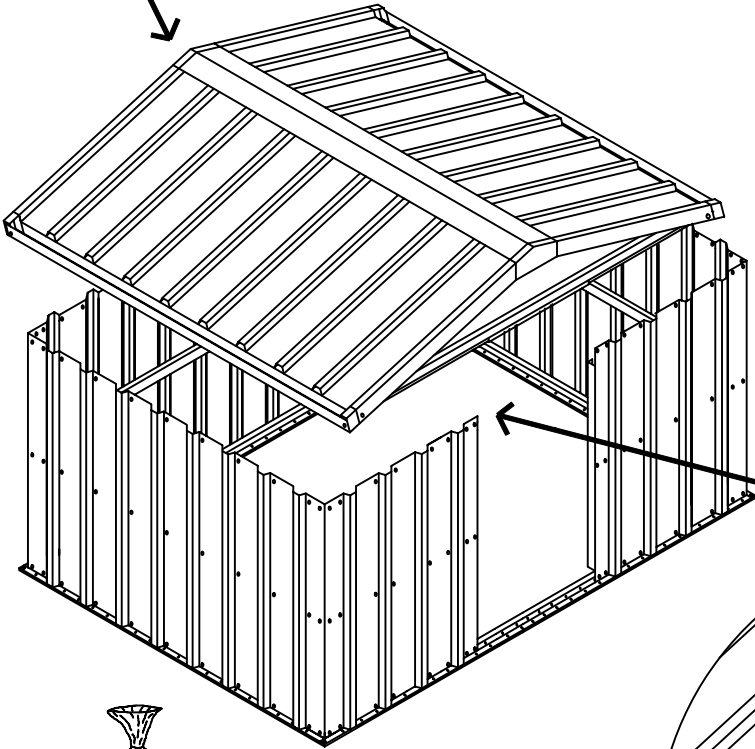
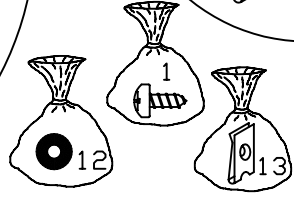
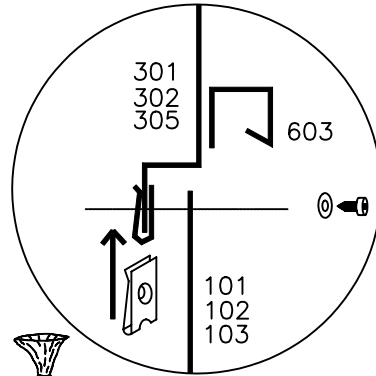
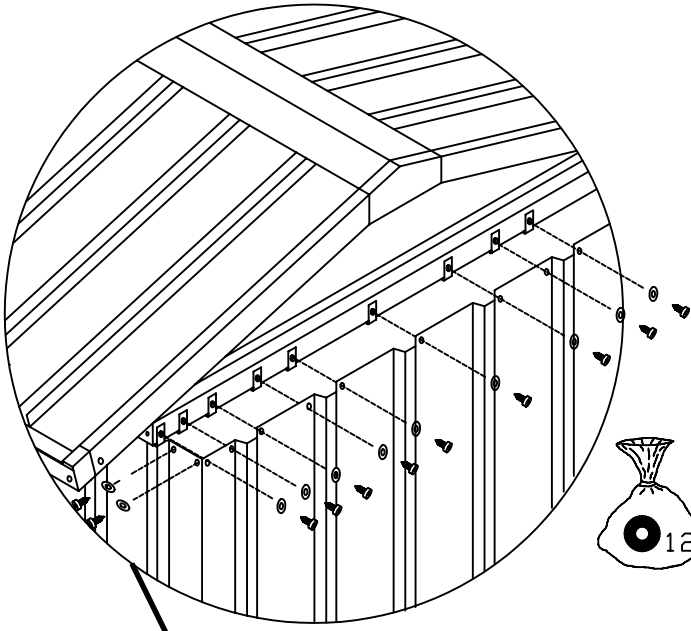
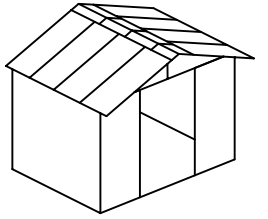

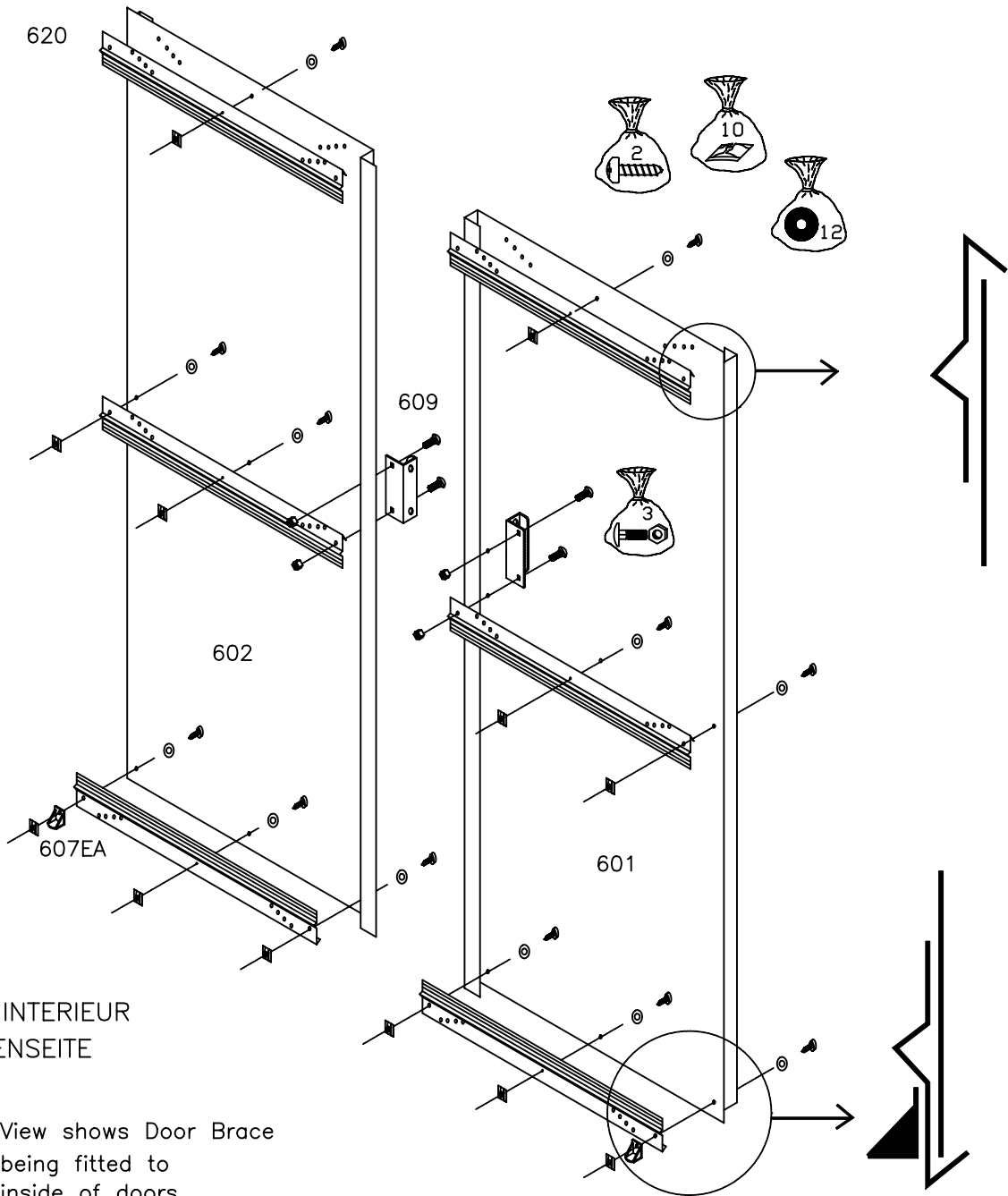

A L'INTERIEUR
INNENSEITE

View shows Door Brace
being fitted to
inside of doors.

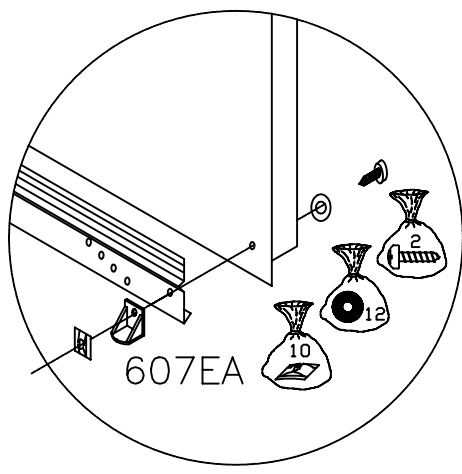
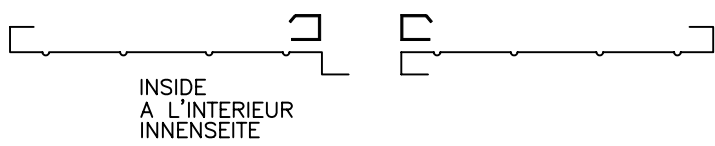

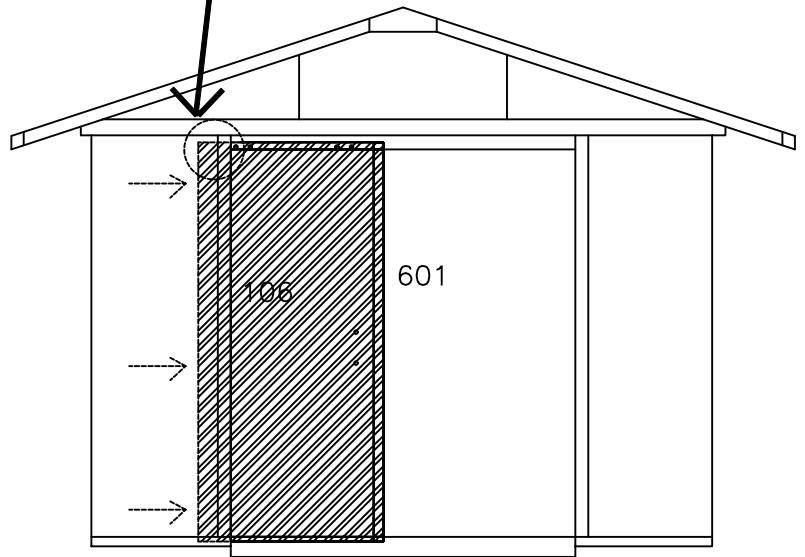
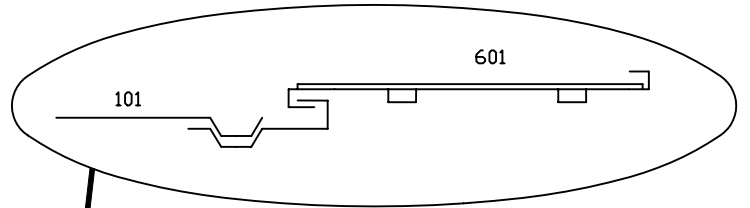
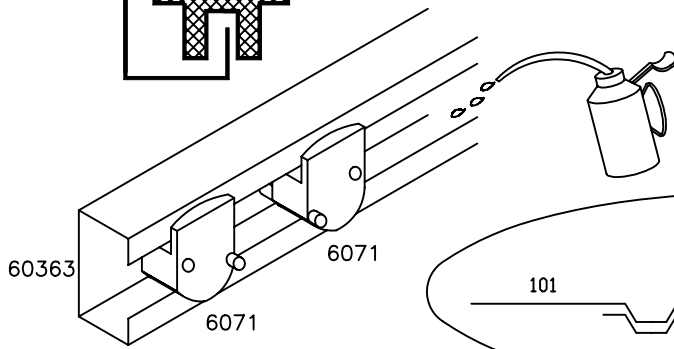
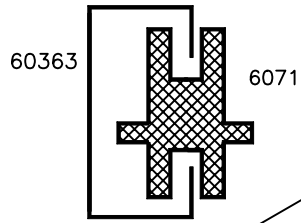

INSIDE
A L'INTERIEUR
INNENSEITE

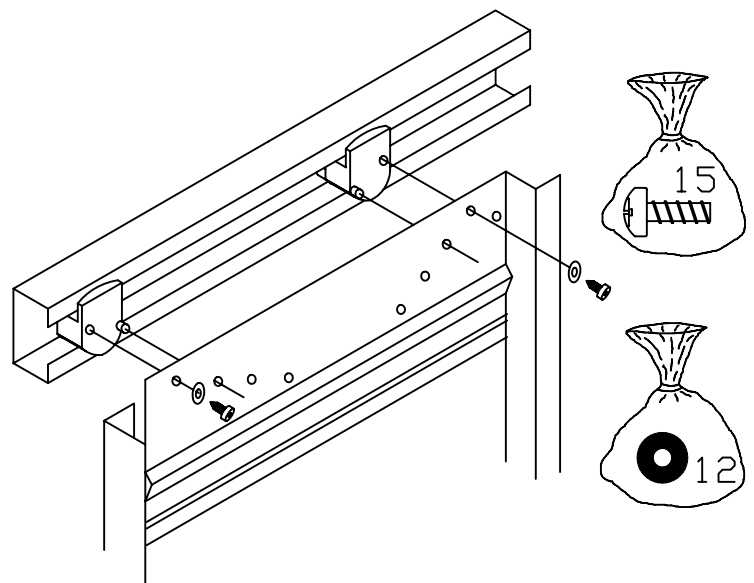
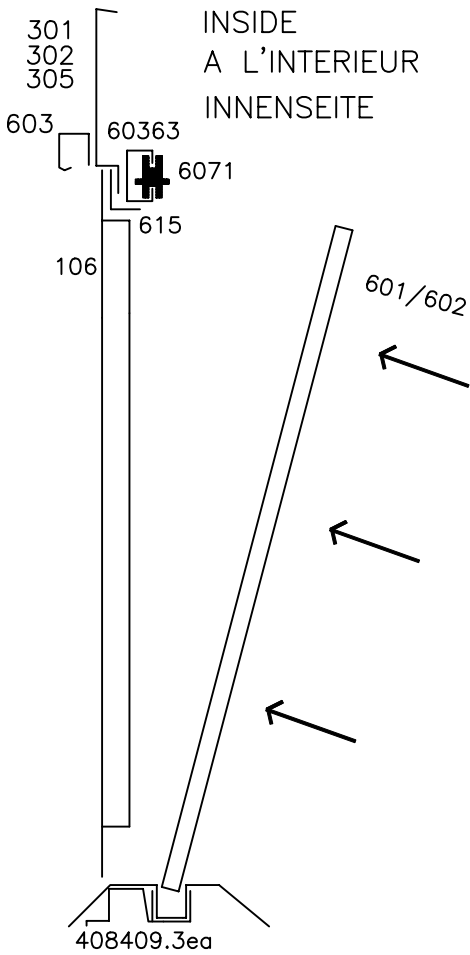

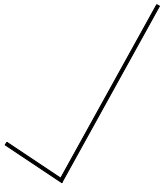
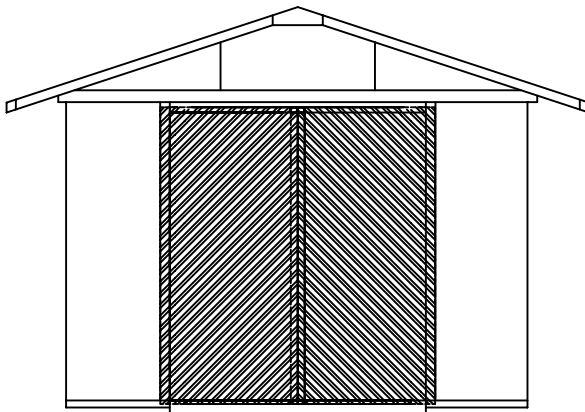
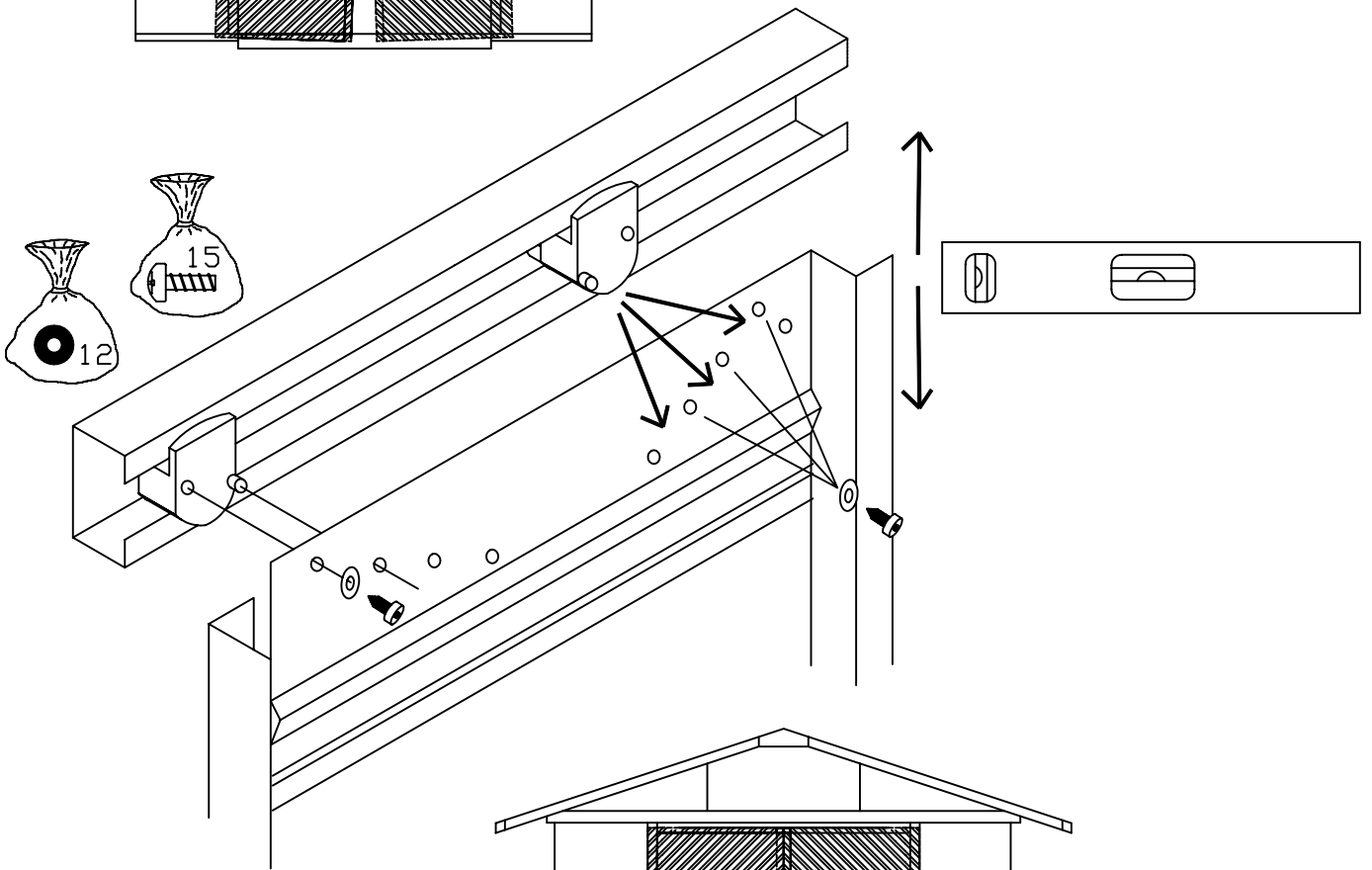
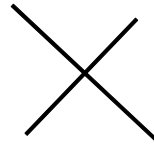
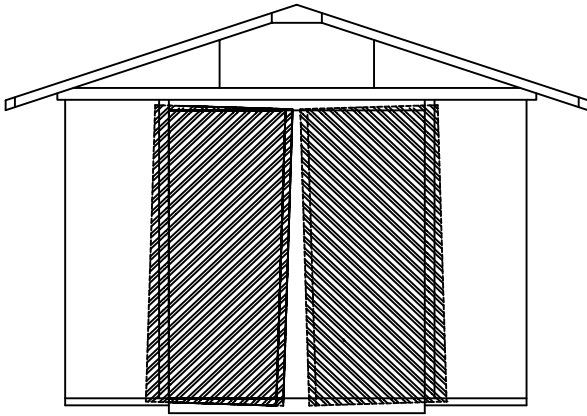

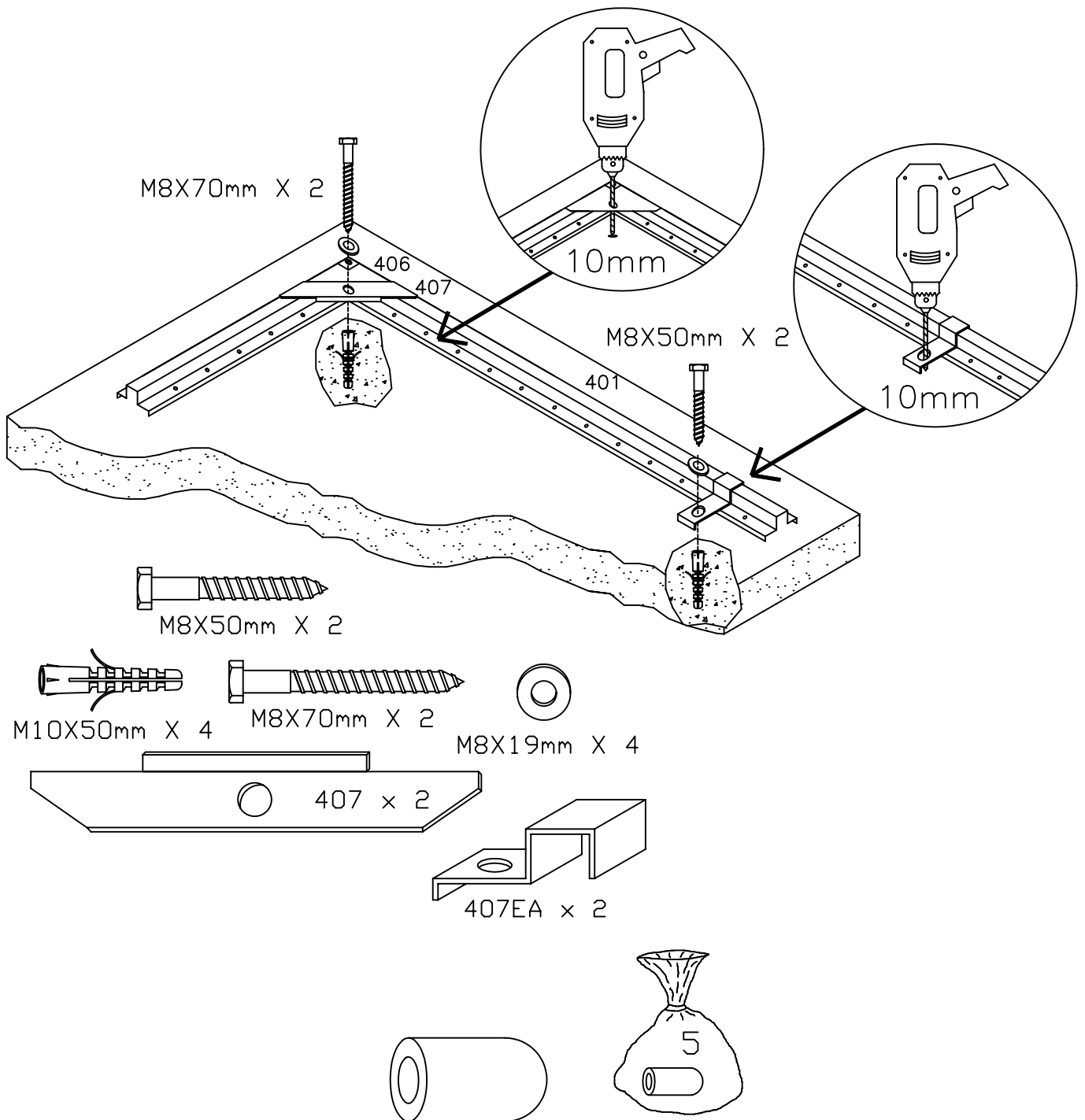

- BAG NO. 5 PLASTIC TIPS USED ON EXPOSED SCREW POINTS ON INSIDE WALLS
- SAC NO. 5 CAPUCHONS EN PLASTIQUE POUR POINTES DE VIS NUES SUR LES PAROIS INTERIEURES
- BEUTEL NO. 5 PLASTIK-AUFSTECKHUTCHEN FUR DIE SCHRAUBENSPIZEN AN DEN INNENWANDEN
- ZAK NO. 5 PLASTIC DOPJES VOOR SCHROEFUITEINDEN AAN DE BINNENWAND
- BOLSA NO. 5 TAPONES DE PLASTICO PARA UTILIZAR EN PUNTOS DONDE QUEDE EXPUESTO EL TORNILLO EN LAS PAREDES INTERIORES
- SACO NO. 5 PONTEIRAS PLASTICAS PARA PONTAS DE PARAFUSOS EXPOSTAS NAS PAREDES INTERIORES